

Frame Charcoal

LBR-AC-1H28-101

Parts Manual

1/3/2025 8:51:31 AM



Table of Contents

[Back Support Assembly.....](#)3
[Components.....](#)4
[Cross Member Assembly.....](#)6
[Foot Rest Assembly.....](#)7
[Hardware Kit.....](#)8
[Lower Base Assembly.....](#)9
[Pivot Arm Assembly.....](#)10
[Pivot Arm Base Assembly.....](#)11
[Rod End Link Assembly.....](#)12
[Work Arm Assembly.....](#)13
[Work Arm Stop Assembly.....](#)14

Back Support Assembly

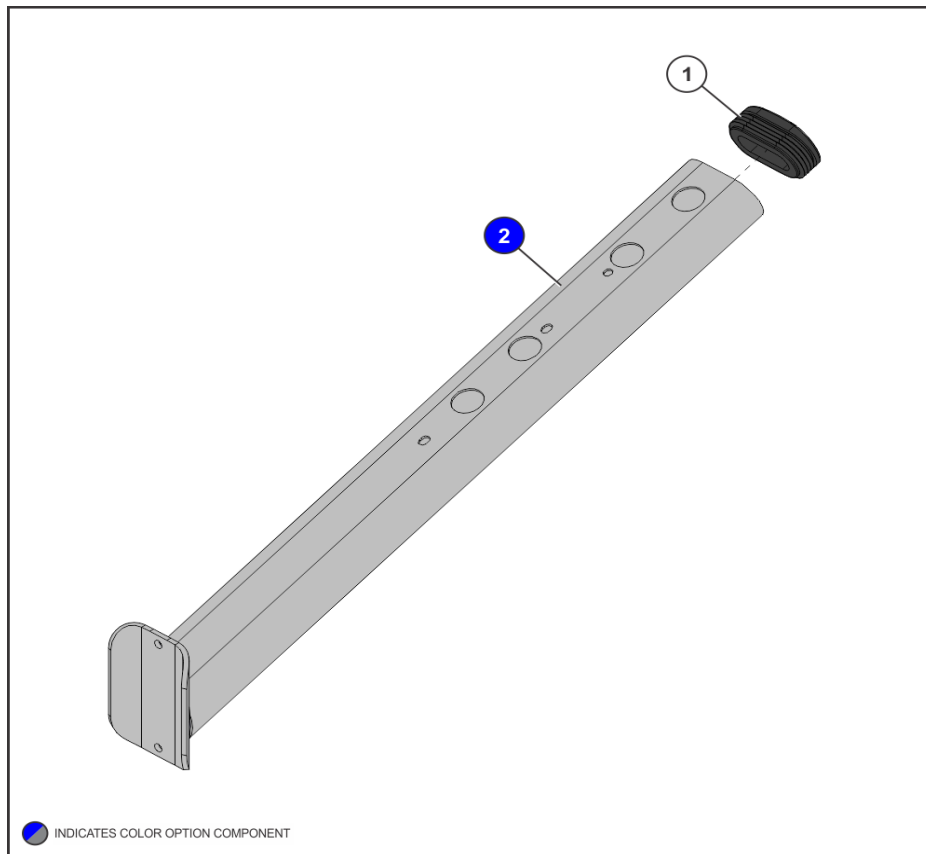

Ref #	Part Number	Qty	Description
1	1022454-0001	1	ENDCAP: FLOV : INJ MOLDED
2	1023966-0000	1	WELDMENT: BACK SUPPORT Custom

Components

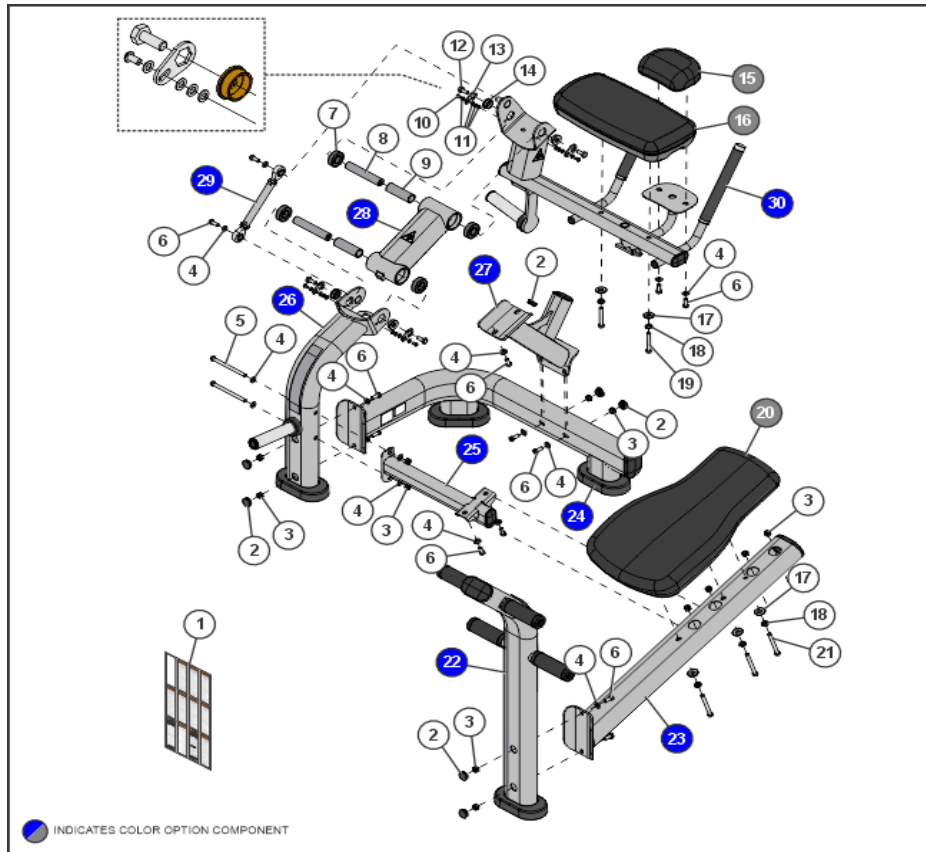

Ref #	Part Number	Qty	Description
1	8137801	1	LABEL, ASTM, OLY VERT-SHEET
2	3237407	7	PLUG, 1 IN HOLE
3	3242002	12	NUT, M10 X 1.5 HEX NYLOCK
4	3102514	18	WASHER, FLAT 3/8 IN SAE ST ZN
5	3256221	2	SCREW, M10 X 1.5 135MM ZN
6	3256202	14	SCREW, M10 X 1.5 25MM ZN
7	3235601	4	BEARING, 6205 BALL
8	9198901	2	SHAFT, SABB PIVOT
9	9199501	2	SPACER, INTERNAL
10	3252803	4	M6-1.0 X 12 HXS BUT CS ST ZN
11	3264101	16	WASHER, M6
12	3270506	4	SCREW, M10 X 1.5 - 25MM, HEX HD 91280A630
13	8852201	4	SHEET, BOLT RETAINER
14	9199401	4	BUSHING, FLANGE, 25MM ID
15	1000002-0199	1	PAD, ARM REST CUS, DBL STITCH- Custom
15	1000002-0101	1	PAD, ARM REST CUS, DBL STITCH- BLACK
15	1000002-0099	1	PAD, ARM REST CUS, SNGL STITCH, Custom
15	1000002-0001	1	PAD, ARM REST CUS, SNGL STITCH, Black
16	1000006-0099	1	PAD, 18 X 9 CONVEX CUS, SNGL STITCH- Custom
16	1000006-0001	1	PAD, 18 X 9 CONVEX CUS, SNGL STITCH- BLACK
16	1000006-0101	1	PAD, 18 X 9 CONVEX CUS, DBL STITCH- BLACK
16	1000006-0199	1	PAD, 18 X 9 CONVEX CUS, DBL STITCH- Custom

Ref #	Part Number	Qty	Description
17	1012186-0001	5	SPACER: 1-1/4 OD X 1/4
18	7630101	5	RETAINER, CM/MJ, PULLEY
19	3256211	2	SCREW, M10 X 1.5 70MM ZN
20	1023984-0199	1	PAD, LARGE BACK, CUS, DOUBLE-STITCH
20	1023984-0101	1	PAD, LARGE BACK, BLACK, DOUBLE-STITCH
20	1023984-0001	1	PAD, LARGE BACK, BLACK, SINGLE-STITCH
20	1023984-0099	1	PAD, LARGE BACK, CUS, SINGLE-STITCH
21	3236217	3	M10 X 1.5 X 100 SHCS, LOW HEAD
22	1023929-0000	1	ASSEMBLY: FOOT REST Custom
23	1023933-0000	1	ASSEMBLY: BACK SUPPORT Custom
24	1023930-0000	1	ASSEMBLY: LOWER BASE Custom
25	1023937-0000	1	ASSEMBLY: CROSS MEMBER Custom
26	1023928-0000	1	ASSEMBLY: PIVOT ARM BASE Custom
27	1023935-0000	1	ASSEMBLY: WORK ARM STOP Custom
28	1024011-0000	1	ASSEMBLY: PIVOT ARM Custom
29	1024013-0000	1	ASSEMBLY: LINK, ROD ENDS Custom
30	1023931-0000	1	ASSEMBLY: WORK ARM Custom

Cross Member Assembly

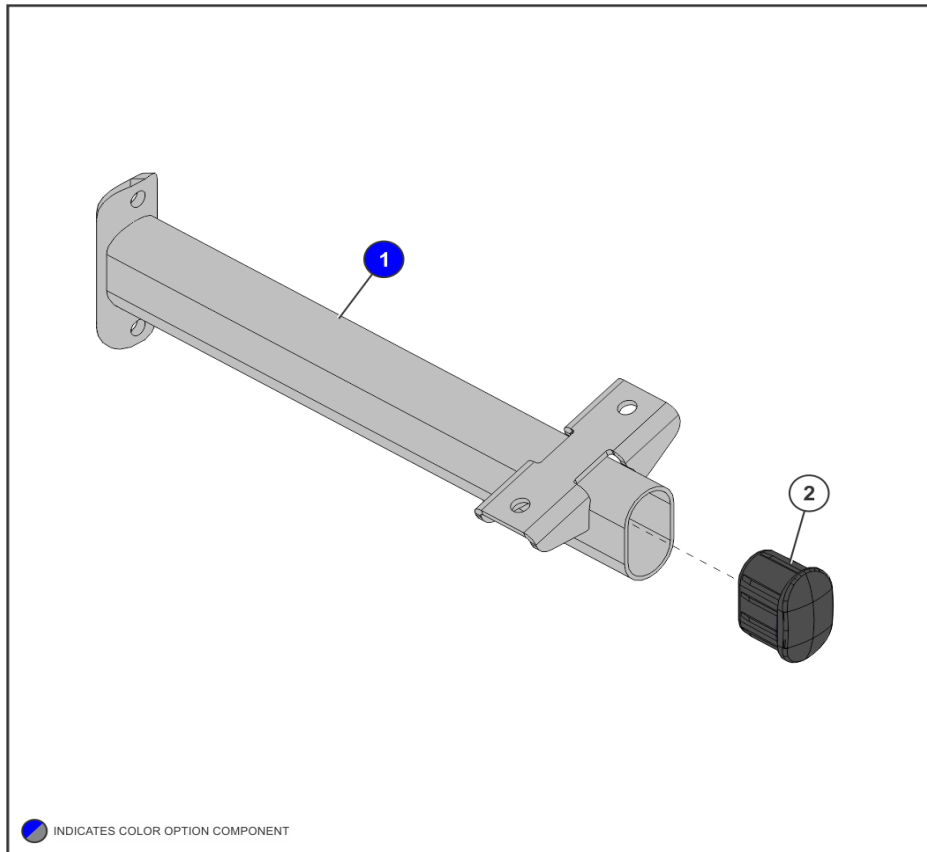

Ref #	Part Number	Qty	Description
1	9197900	1	WLDMT, SABB CROSS MEMBER Custom
2	7800502	1	CAP, SML FLOV END -CHR

Foot Rest Assembly

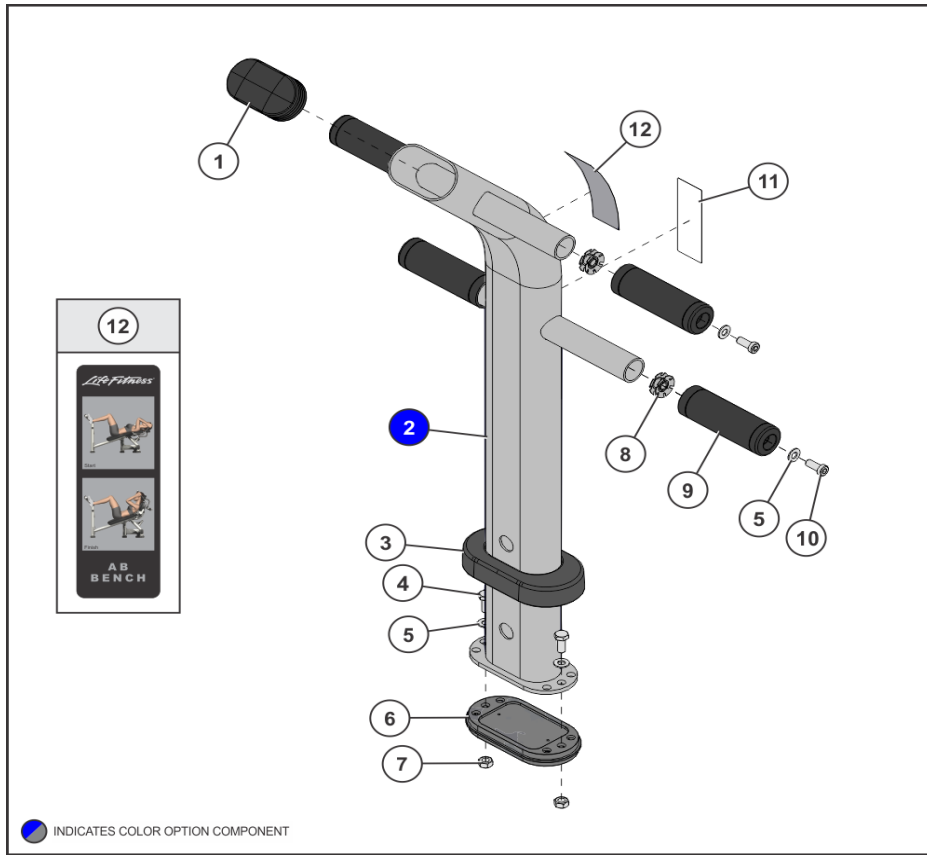

Ref #	Part Number	Qty	Description
1	1022454-0001	1	ENDCAP: FLOV : INJ MOLDED
2	1023944-0000	1	WELDMENT: FOOT REST Custom
3	7340201	1	COVER, FOOT - STRAIGHT
4	3251202	2	M10 X 1.5 X 25MM UNS HEX CS ST ZN
5	3102514	6	WASHER, FLAT 3/8 IN SAE ST ZN
6	LEA7763001	1	FOOT: 2.50 X 4.49
7	3254703	2	NUT, M10 X 1.5 HEX ZINC
8	7347301	4	NUT, SPIDER M10 X 1.5
9	7800102	4	GRIP, 1.50 ID FOOT
10	3256202	4	SCREW, M10 X 1.5 25MM ZN
11	8137801	1	LABEL, ASTM, OLY VERT-SHEET
12	9202001	1	LABEL, SABB PLACARD

Hardware Kit

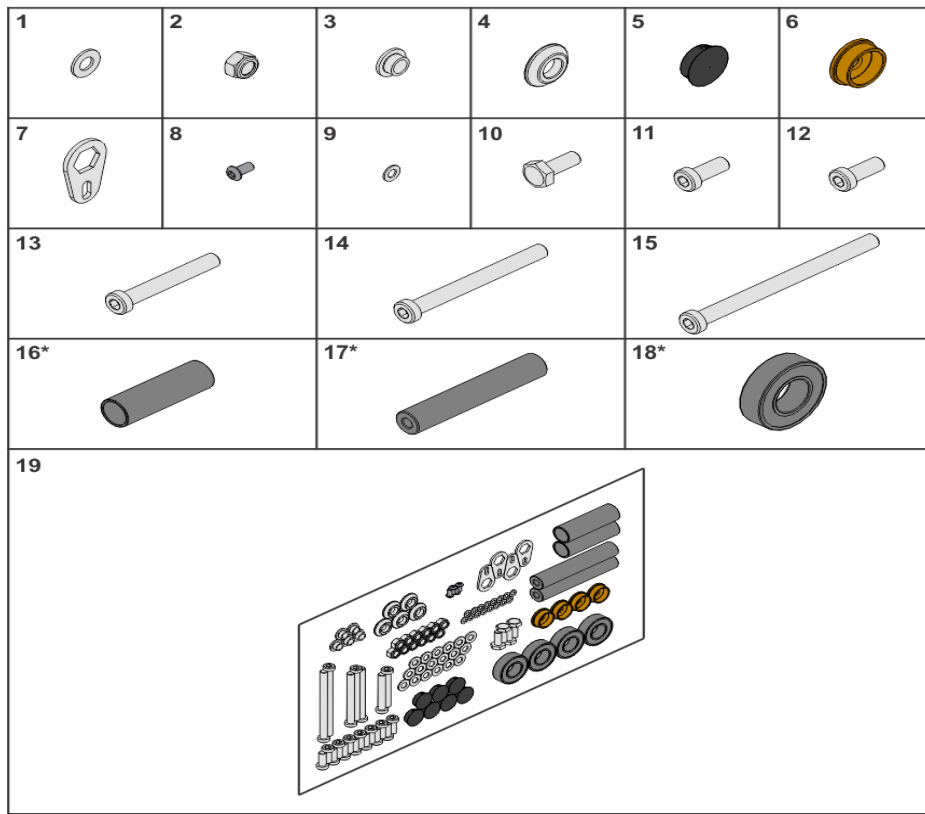

* COMES INSTALLED IN THE PIVOT ARM

Ref #	Part Number	Qty	Description
1	3102514	18	WASHER, FLAT 3/8 IN SAE ST ZN
2	3242002	12	NUT, M10 X 1.5 HEX NYLOCK
3	7630101	5	RETAINER, CM/MJ, PULLEY
4	1012186-0001	5	SPACER: 1-1/4 OD X 1/4
5	3237407	7	PLUG, 1 IN HOLE
6	9199401	4	BUSHING, FLANGE, 25MM ID
7	8852201	4	SHEET, BOLT RETAINER
8	3252803	4	M6-1.0 X 12 HXS BUT CS ST ZN
9	3264101	16	WASHER, M6
10	3270506	4	SCREW, M10 X 1.5 - 25MM, HEX HD 91280A630
11	3256201	14	SCREW, M10 X 1.5 X 1.5 20MM ZN
12	3256202	14	SCREW, M10 X 1.5 25MM ZN
13	3256211	2	SCREW, M10 X 1.5 70MM ZN
14	3236217	3	M10 X 1.5 X 100 SHCS, LOW HEAD
15	3256221	2	SCREW, M10 X 1.5 135MM ZN
16	9199501	2	SPACER, INTERNAL
17	9198901	2	SHAFT, SABB PIVOT
18	3235601	4	BEARING, 6205 BALL
19	1024338-0001	1	KIT: HARDWARE

Lower Base Assembly

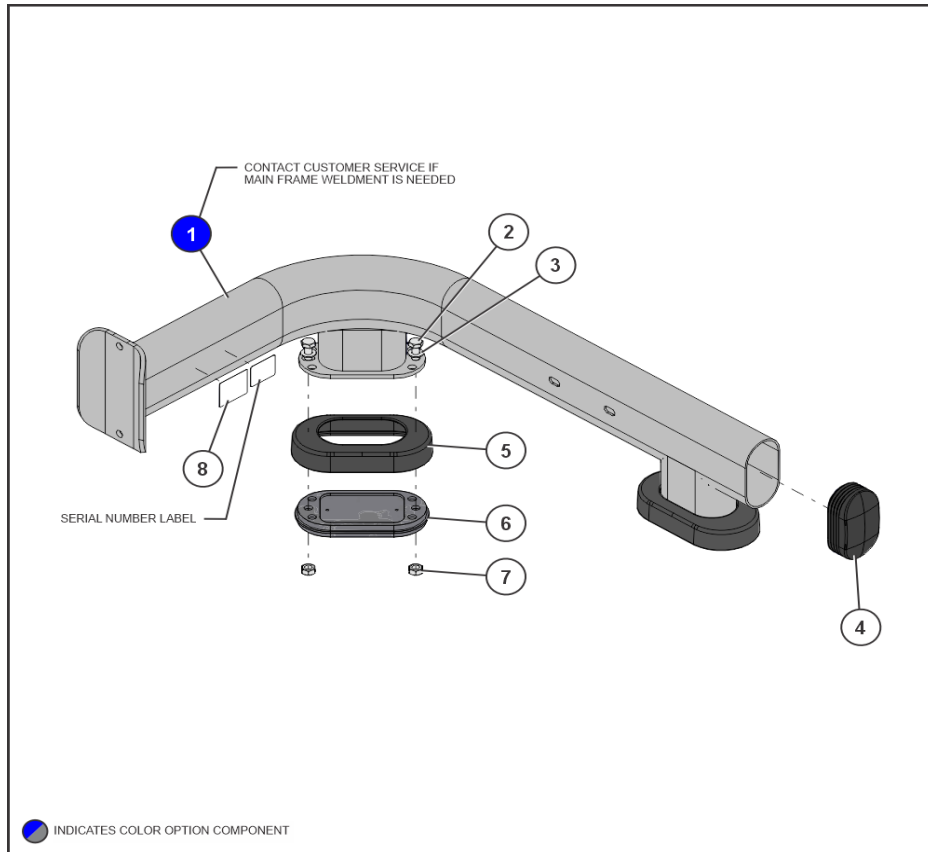

Ref #	Part Number	Qty	Description
1	9197200	1	WLDMT, SABB LOWER BASE Custom
2	3251202	4	M10 X 1.5 X 25MM UNS HEX CS ST ZN
3	3102514	4	WASHER, FLAT 3/8 IN SAE ST ZN
4	1022454-0001	1	ENDCAP: FLOV : INJ MOLDED
5	7340202	2	COVER, FOOT, STRAIGHT -BLK
6	LEA7763001	2	FOOT: 2.50 X 4.49
7	3254703	4	NUT, M10 X 1.5 HEX ZINC
8	9488901	1	LABEL, INSIGNIA, FCC

Pivot Arm Assembly

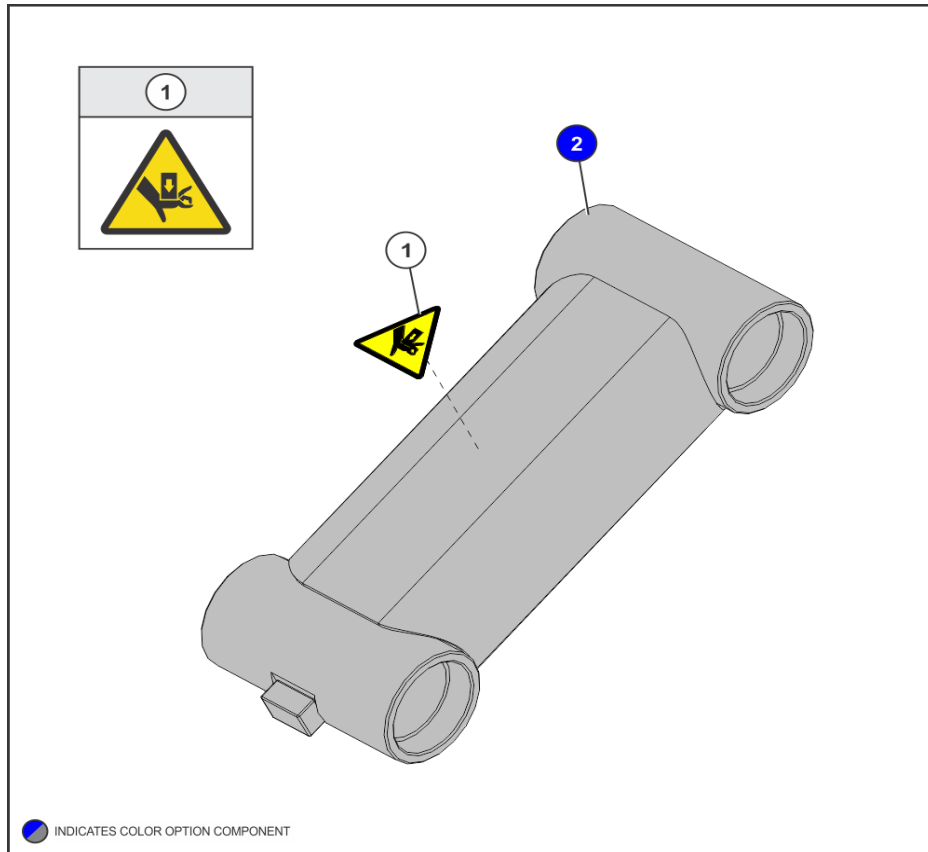

Ref #	Part Number	Qty	Description
1	8039501	1	LABEL, WARNING TRIANGLE
2	9195400	1	WLDMT, SABB PIVOT ARM Custom

Pivot Arm Base Assembly

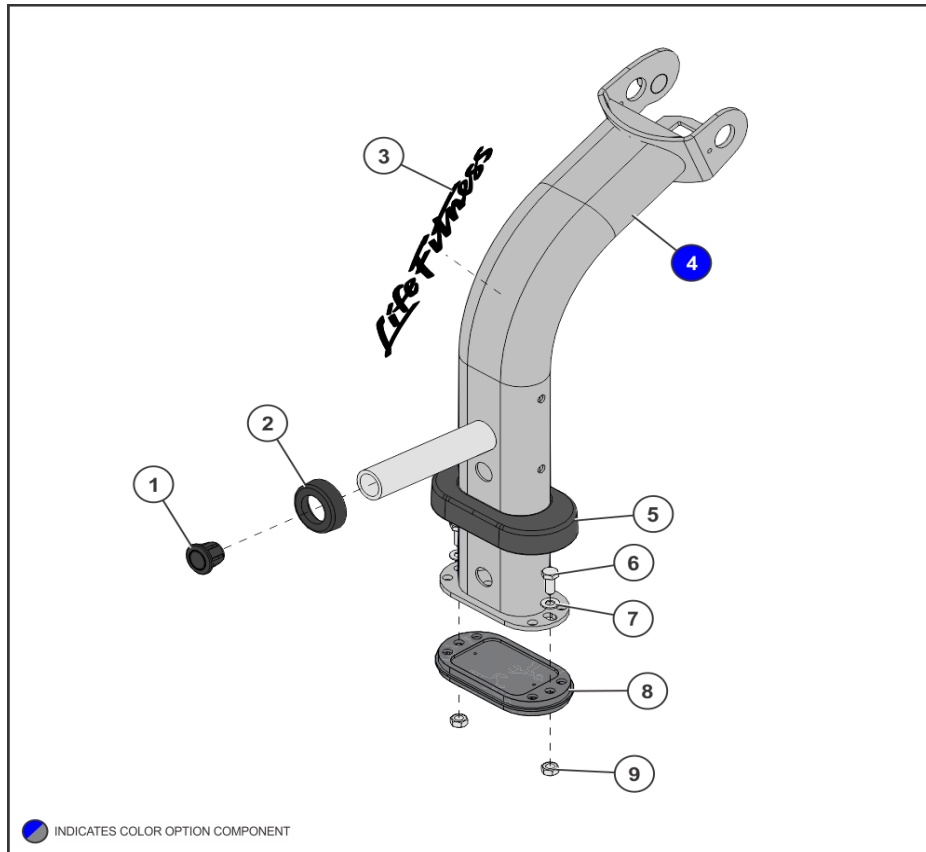

Ref #	Part Number	Qty	Description
1	7800302	1	PLUG, WT HORN-CHR
2	7800202	1	RING, WT HORN-CHR
3	7865201	1	LABEL, LIFE FITNESS LOGO, 10-0099-062, BNR
4	9194600	1	WLDMT, SABB PIVOT ARM BASE Custom
5	7340202	1	COVER, FOOT, STRAIGHT -BLK
6	3251202	2	M10 X 1.5 X 25MM UNS HEX CS ST ZN
7	3102514	2	WASHER, FLAT 3/8 IN SAE ST ZN
8	LEA7763001	1	FOOT: 2.50 X 4.49
9	3254703	2	NUT, M10 X 1.5 HEX ZINC

Rod End Link Assembly

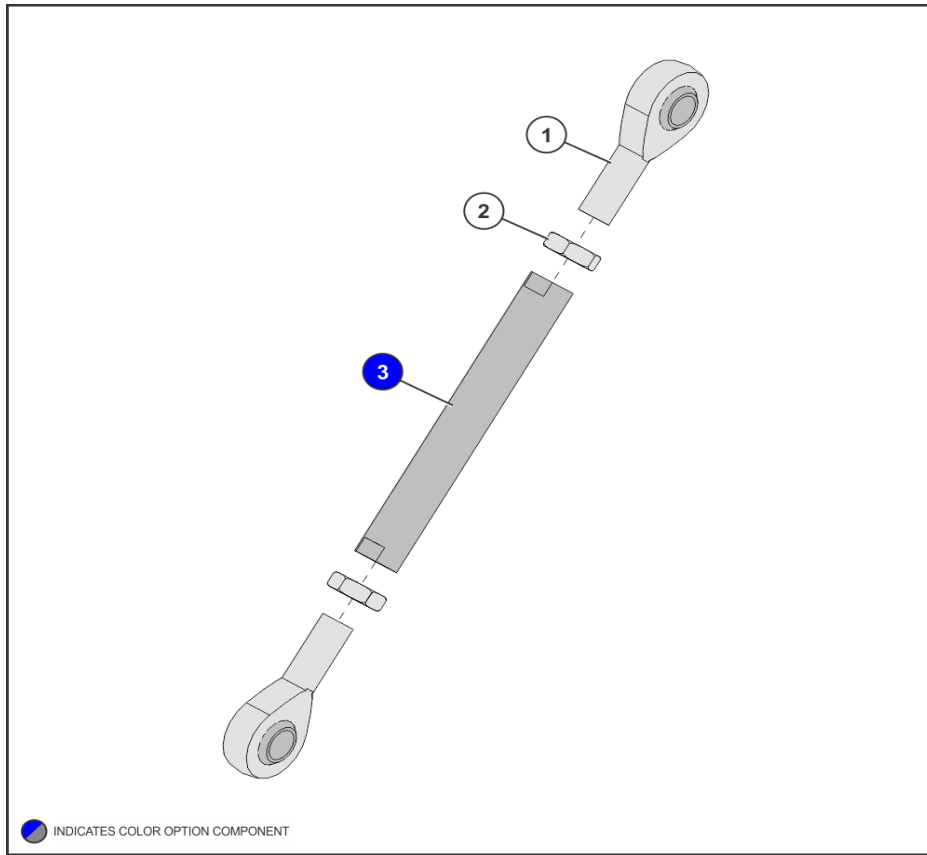

Ref #	Part Number	Qty	Description
1	3238701	2	ROD END, METRIC MALE
2	3236902	2	NUT, HEX JAM M16 X 2 SS
3	9198899	1	TUBE, SABB LINK- Custom

Work Arm Assembly

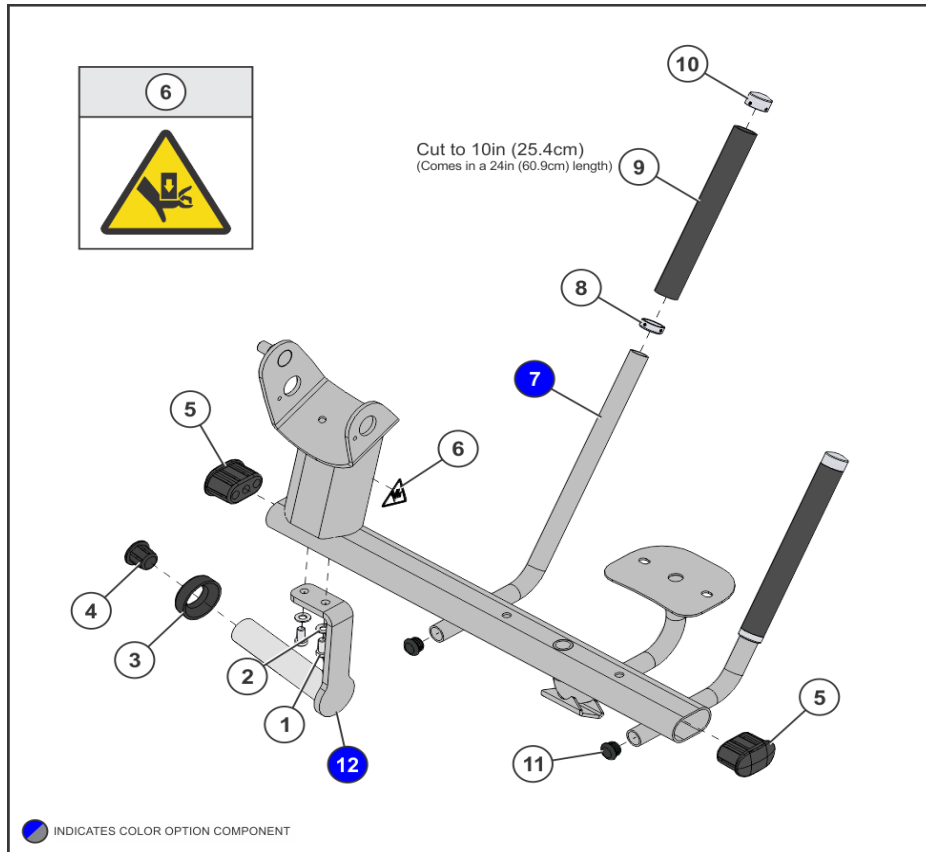

Ref #	Part Number	Qty	Description
1	3256201	2	SCREW, M10 X 1.5 X 1.5 20MM ZN
2	3102514	2	WASHER, FLAT 3/8 IN SAE ST ZN
3	7800202	1	RING, WT HORN-CHR
4	7800302	1	PLUG, WT HORN-CHR
5	7800502	2	CAP, SML FLOV END -CHR
6	8039501	1	LABEL, WARNING TRIANGLE
7	1023968-0000	1	WELDMNT: WORK ARM Custom
8	7662801	2	RING, GRIP 1.25 OD
9	3235806	2	GRIP, 1.25 OD X .125 WALL OPEN END
10	7662901	2	CAP; GRIP 1.25 OD
11	3119304	2	CAP, END 1 DIA RD 10-12GA
12	9199200	1	WLDMT, SABB WEIGHT HORN Custom

Work Arm Stop Assembly

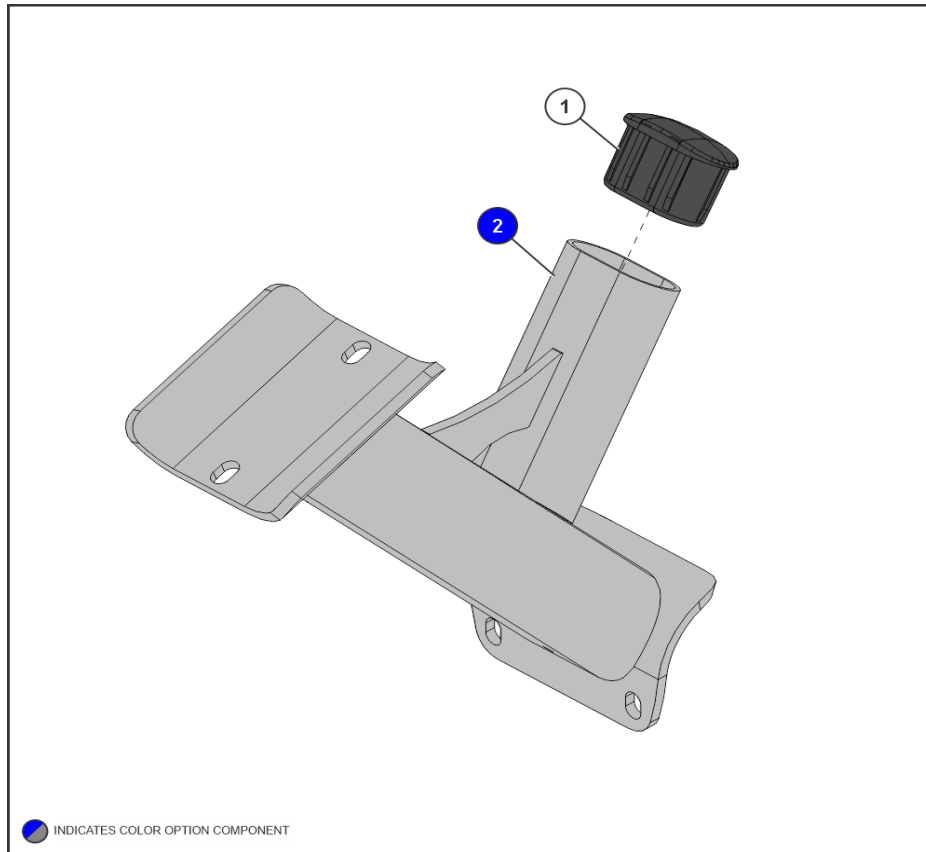

Ref #	Part Number	Qty	Description
1	7800502	1	CAP, SML FLOV END -CHR
2	9196600	1	WLDMT, SABB WORK ARM STOP Custom

