

# PLANET FITNESS INTEGRITY TREAD SL FRN DLV 1BOX

INT-SL-FRN-DLV-11PF

## Parts Manual

2/5/2024 23:08:09 PM



**LifeFitness**  
WHAT WE LIVE FOR

## Table of Contents

---

<a href="#">A Legend Description</a> .....	3
<a href="#">Base Frame Electronics</a> .....	4
<a href="#">Bridge Shrouds</a> .....	6
<a href="#">Bridge, Upright, and Grounding Braid Cables</a> .....	7
<a href="#">Bullhorns</a> .....	9
<a href="#">Console Rear Shrouds</a> .....	10
<a href="#">Deck, Rails, and End Caps</a> .....	11
<a href="#">Drive Motor, Pulley, and Rollers</a> .....	13
<a href="#">Lift Frame, Leg Levelers, and Wheels (HHT, CHT, TIC, TIB)</a> .....	14
<a href="#">Lift Frame, Leg Levelers, and Wheels (PHM)</a> .....	15
<a href="#">Lower Base Wiring Diagram</a> .....	16
<a href="#">Power Cords</a> .....	18
<a href="#">Service Wheel (HHT and TIB)</a> .....	19
<a href="#">Upper Base with Integrity SL and Discover SE4 Consoles Wiring</a> .....	20

# A Legend Description

<b>Integrity Base Finished Good Example: INT-SSL-ASLHM-SW11AR</b>											
<b>IN</b>	<b>T</b>	<b>S</b>	<b>SL</b>	<b>ASL</b>	<b>H</b>	<b>M</b>	<b>SW</b>	<b>11</b>	<b>AR</b>		
PRODUCT LINE: Integrity (IN) Club Series Plus (CS)	BASE TYPE: Treadmill (T) Cross-Trainer (X) Recumbent Bike (R) Upright Bike (C)	STYLE: Simple (S) Deluxe (D)	CONSOLE CAPABILITY: Integrity SL (SL) Entertainment (E) Discover ST or SE3HD	COLOR: Arctic Silver (ASL) Titanium (TTN) Black (BLK) Diamond White (DWT)	VOLTAGE: High (H) Low (L)	GENERATION: McFly (M) Legacy (X)	SERVICE WHEEL	REVISION	LANGUAGE: Arabic (AR) English unless other language specified		
<b>Integrity Base Finished Good Example: INT-SST-ALLXX-11</b>					<b>LF Arc Base Finished Good Example: INTLS-ALLXX-7101</b>						
<b>IN</b>	<b>T</b>	<b>S</b>	<b>ST</b>	<b>ALL</b>	<b>X</b>	<b>11</b>	<b>IN</b>	<b>TLS</b>	<b>ALL</b>	<b>XX</b>	<b>7101</b>
PRODUCT LINE: Integrity (IN) Club Series Plus (CS)	BASE TYPE: Treadmill (T) Cross-Trainer (X) Recumbent Bike (R) Upright Bike (C)	STYLE: Simple (S) Deluxe (D)	CONSOLE CAPABILITY: Discover ST (ST) Discover SE3HD (SE) Integrity SL (SL)	LANGUAGE: All Languages (ALL)	VERSION: McFly (M) Legacy (X)	REVISION	PRODUCT LINE: Integrity (IN)	BASE TYPE: Advanced Base (AT) Basic Base (TS) Total Body (TS) Lower Body (LS)	STANDARD: No High or low voltage	CONSOLE CAPABILITY: Integrity C/A (CX) Discover SE3HD/ST (XX) Integrity SL (XM)	COLOR: Diamond White (7101) Titanium Storm (7201) Arctic Silver (5101) Black Onyx (7301) PF Purple (5801)
<b>Integrity Item Description Example: ARB INT TREAD SIMPLE SL ARC SIL HIGH VT SW BASE UK</b>											
<b>ARB</b>	<b>INT</b>	<b>TREAD</b>	<b>SIMPLE</b>	<b>SL</b>	<b>ARC SIL</b>	<b>HIGH VT</b>	<b>SW</b>	<b>BASE</b>	<b>UK</b>		
LANGUAGE: Arabic (ARB) English unless other language specified	PRODUCT LINE: Integrity (INT) Club Series Plus (CS)	BASE TYPE: Treadmill (TREAD) Cross-Trainer (X / TT) Recumbent Bike (R / RB) Upright Bike (C / UB)	STYLE: Simple (S) Deluxe (DLX)	CONSOLE CAPABILITY: Integrity SL (SL) Discover ST or Discover SE3HD (DSC)	COLOR: Arctic Silver (ARC SIL) Titanium (TTN) Black (BLK) Diamond White (DIA WHT)	VOLTAGE: High (High VT) Low (Low VT)	SERVICE WHEEL	PRODUCT TYPE: Base	LINE CORD: UK High Voltage (UK) Argentina (ARG) Domestic Low Voltage (DLV)		
<b>Aspire Base Finished Good Example: ASPT-ASLLN-12</b>						<b>SL Console Finished Good Example: SLA-CNSL-ENG-01</b>					
<b>ASP</b>	<b>T</b>	<b>ASL</b>	<b>L</b>	<b>N</b>	<b>12</b>	<b>SL</b>	<b>A</b>	<b>CNSL</b>	<b>ENG</b>	<b>01</b>	
PRODUCT LINE: Aspire (ASP)	BASE TYPE: Treadmill (T) Cross-Trainer (X) Upright Bike (C) Recumbent Bike (R)	COLOR: Arctic Silver (ASL) Charcoal (CGC)	VOLTAGE: Low (L) High (H)	VERSION: Neo (N)	REVISION	CONSOLE TYPE: Integrity SL (SL)	BASE TYPE: Arc (A) Tread (T) PowerBall (P) Cross-Trainer / Bikes (XB)	Console (CNSL)	LANGUAGE: Three character language abbreviation	REVISION	
<b>SE4 Console Finished Good Example: SE424T-EWXXP-01</b>											
<b>SE4</b>	<b>24</b>	<b>T</b>	<b>E</b>	<b>W</b>	<b>X</b>	<b>X</b>	<b>P</b>	<b>01</b>			
CONSOLE TYPE: Discover SE4 (SE4)	CONSOLE SIZE: 24 16	BASE TYPE: Tread (T) Non Tread (N)	LANGUAGE (Warning Label) English (E) All (A)	WIFI ENABLED: Wifi Enabled (W)	NFC or RFD: NFC (X) RFD (R)	PLACEHOLDER	TUNER TYPE: PROIDIOM/DAM (P) DVBT2/DVB/C/DVBS/PAL/SECAM (D) ISDBT/ATSC (S) STB/SYNC (I) ATSC/DAM/NTSC (A) (on SE4/SE3HD/ST only) PROIDIOM OVER ETHERNET (E) (on SE4 only)	REVISION			

Ref #	Part Number	Qty	Description
-	LEGEND_DESCRIP TION	1	LEGEND DESCRIPTION

## Base Frame Electronics

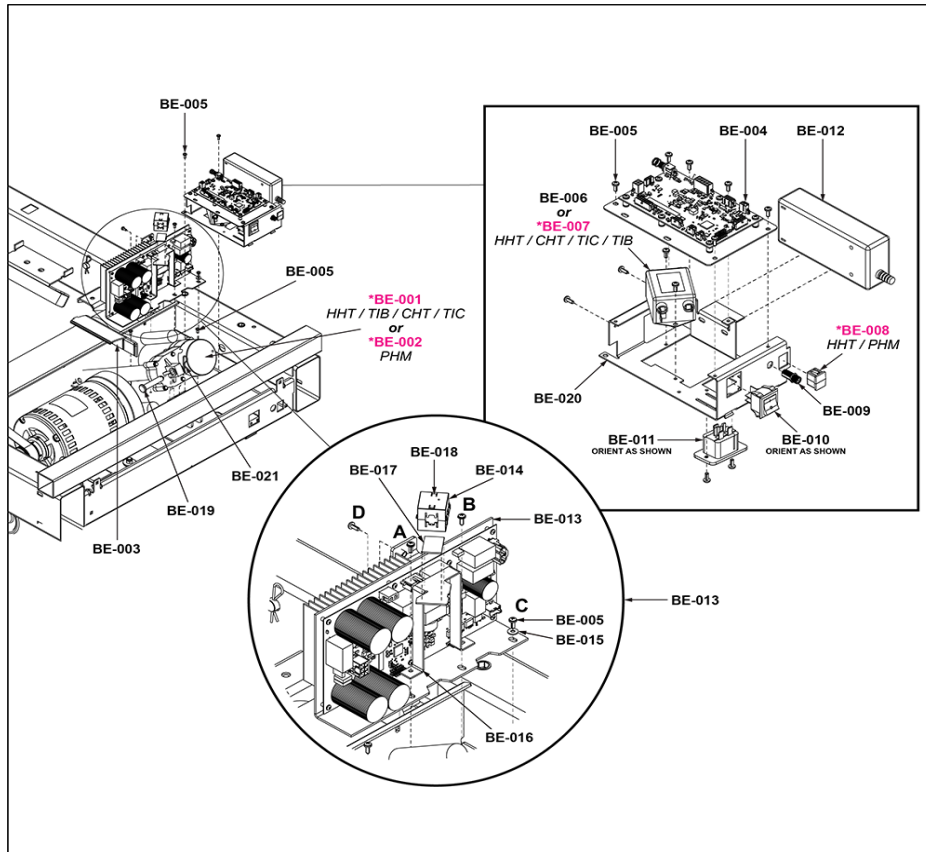

Ref #	Part Number	Qty	Description
BE-001	1001013-0001	1	ACTUATOR: LINEAR, 115V
BE-001	1001013-0002	1	ACTUATOR: LINEAR, 230V
BE-002	1001013-0003	1	ACTUATOR: LINEAR, 115V
BE-002	1001013-0004	1	ACTUATOR: LINEAR, 230V
BE-003	1003261-0001	1	COVER: ACTUATOR, TOP
BE-004	1004381-0002	1	NC ASSEMBLY: SIB PCB ASSY, MCFLY
BE-005	0017-00101-1968	20	SCREW: M4 X 0.7 X 10, PHL, PAN, TT, ST, ZS
BE-006	0017-00003-1015	1	FILTER: LINE, 20A, 250VAC
BE-007	0017-00003-0898	1	FILTER: LINE, 10A
BE-008	1004601-0001	1	PLUG: RJ45 RECEPTACLE
BE-009	0017-00021-2846	1	CONNECTOR: COAX, PANEL MOUNT
BE-010	0017-00032-0198	1	SWITCH: POWER, DPST ROCKER
BE-011	0017-00003-0949	1	RECEPTACLE: IEC, SIDE, FLANGE
BE-012	1011106-0001	1	POWER SUPPLY: 24VDC, 5A
BE-013	1003844-0001	1	NC ASSEMBLY: MDB, PC BOARD ASSY, TREADMILL
BE-014	121E-00001-0010	1	FERRITE-BEAD: SUPPRESSION B
BE-015	1005472-0001	3	WASHER: M4.4 X 11 X 1, ST, ZN
BE-016	1006254-0001	1	BRACKET: FERRITE CORE
BE-017	0017-00081-0346	1	TAPE: ADHESIVE, DOUBLE-SIDED
BE-018	0017-00042-1082	1	CABLE-TIE: L=15-5/16 IN. S/C#09-B
BE-019	1012811-0001	1	PIN: M12, CLEVIS
BE-020	1003724-0001	1	BRACKET: ELECTRICAL MTG.

<b>Ref #</b>	<b>Part Number</b>	<b>Qty</b>	<b>Description</b>
BE-021	1004469-0001	1	PIN: M10 X 50, COTTER

## Bridge Shrouds

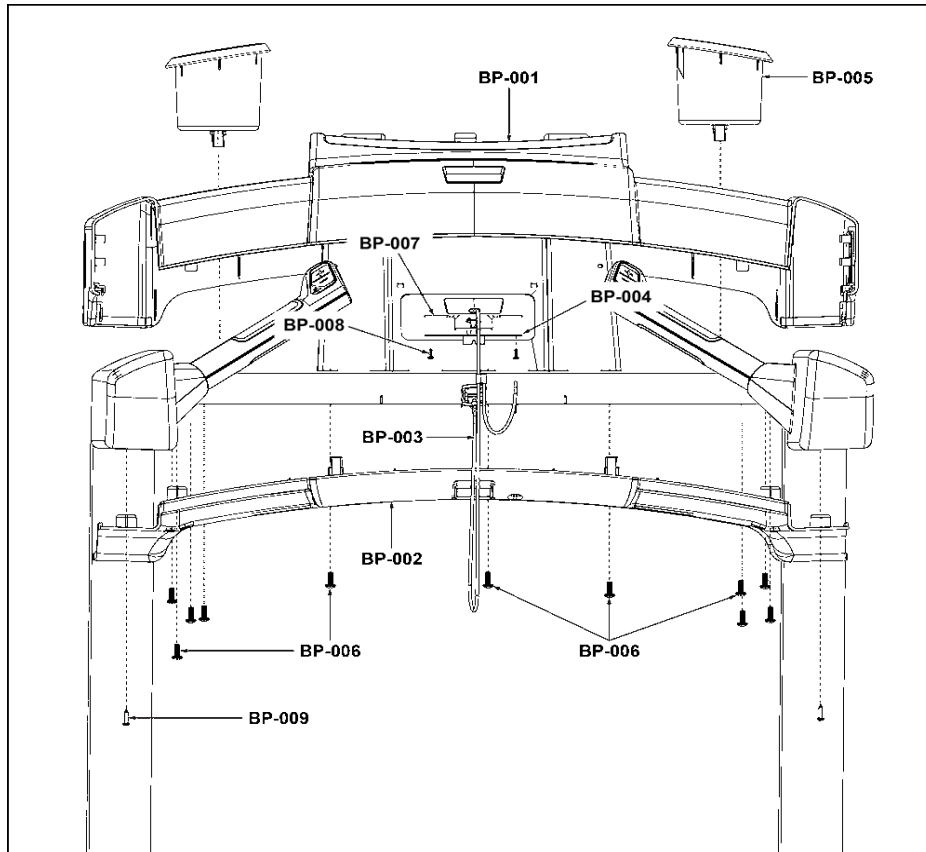

Ref #	Part Number	Qty	Description
BP-001, BP-002	1009938-0001	2	ASSEMBLY: MIDDLE SHROUDS
BP-003	1002224-0000	1	ASSEMBLY: TETHER, ASSEMBLY
BP-004	1002228-0001	1	PLATE: TETHER, PLATE
BP-005	1001740-2400	2	SHROUD: CUP HOLDER, CHARCOAL GRAY
BP-006	0017-00101-2138	13	SCREW: M6 X 1.0 X 16, DIN, PHL, PAN, MS, ST, ZB
BP-007	1005621-0001	1	BRACKET: REED SWITCH MOUNTING
BP-008	0017-00101-1650	2	SCREW: 6-19 X 6, PHL, PAN, PLT, ST, ZB, VMI
BP-009	0017-00101-1796	2	SCREW: M4.2 X 0.7 6G6G X 19, DIN, PHL, PAN, AB, ST, ZB

## Bridge, Upright, and Grounding Braid Cables

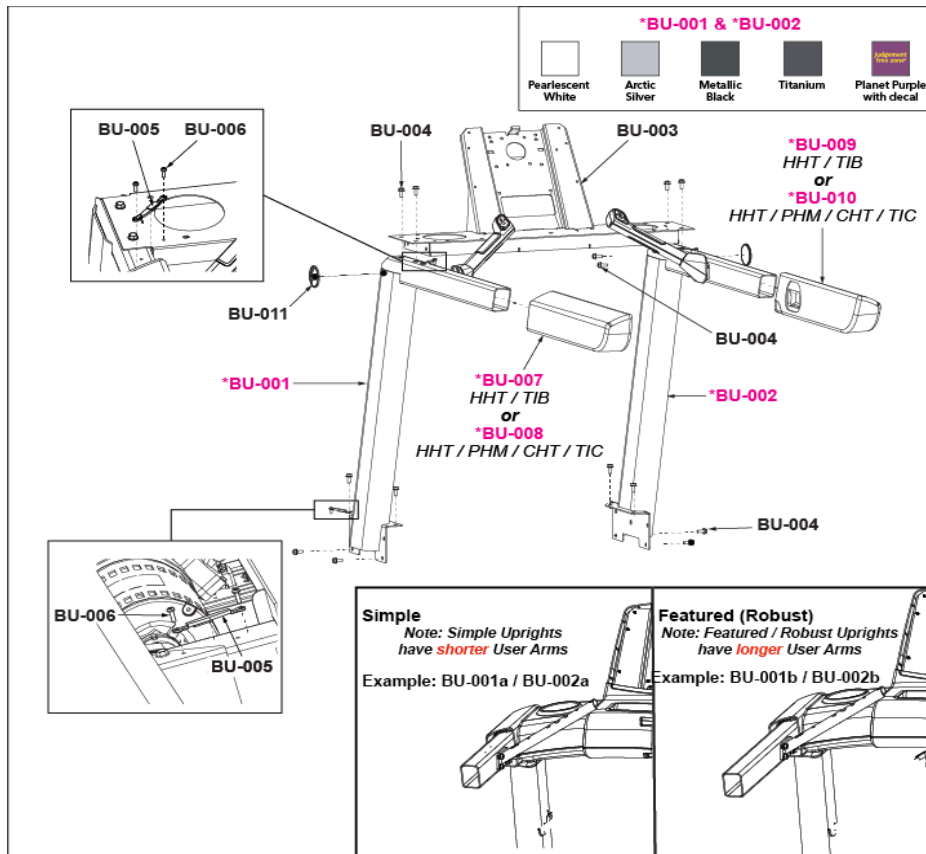

Ref #	Part Number	Qty	Description
BU-001	1014190-0001	1	ASSEMBLY: UPRIGHT W/INSERT, LEFT, TITANIUM
BU-001	1014188-0001	1	ASSEMBLY: UPRIGHT W/INSERT, LEFT, ARCTIC SILVER
BU-001	1014189-0001	1	ASSEMBLY: UPRIGHT W/INSERT, LEFT, PEARLESCENT WHITE
BU-001	1014191-0001	1	ASSEMBLY: UPRIGHT W/INSERTS; LEFT, METALLIC BLACK
BU-001	1014192-0001	1	ASSEMBLY: UPRIGHT W/INSERTS; LEFT, ARCTIC SILVER
BU-001	1012982-0001	1	ASSEMBLY: UPRIGHT W/DECAL, LEFT, PLANET
BU-002	1014186-0001	1	ASSEMBLY: UPRIGHT W/INSERTS; RIGHT, TITANIUM
BU-002	1014194-0001	1	ASSEMBLY: UPRIGHT W/INSERTS; RIGHT, ARCTIC SILVER
BU-002	1014187-0001	1	ASSEMBLY: UPRIGHT W/INSERT; RIGHT, METALLIC BLACK
BU-002	1014184-0001	1	ASSEMBLY: UPRIGHT W/INSERTS; RIGHT, ARCTIC SILVER
BU-002	1014185-0001	1	ASSEMBLY: UPRIGHT W/INSERT; RIGHT, PEARLESCENT WHITE
BU-002	1012985-0001	1	ASSEMBLY: UPRIGHT W/DECAL, RIGHT, PLANET
BU-003	1001825-0000	1	WELDMENT: BRIDGE
BU-004	1005191-0001	16	SCREW: M8 X 1.25 6G6H X 20, UNS, HXW, CS, ST
BU-005	1006261-0001	4	CABLE: GROUNDING BRAID

<b>Ref #</b>	<b>Part Number</b>	<b>Qty</b>	<b>Description</b>
BU-006	0017-00101-1986	8	SCREW: M5 X 0.8-6G6G X 16, DIN, PAN, TT, ST, ZN
BU-007	1004665-0000	1	GRIP: LEFT, USER ARM, FOAM SIMPLE
BU-008	1001829-0000	1	GRIP: USER ARM, LEFT, FOAM, FEATURED
BU-009	1004666-0000	1	GRIP: RIGHT, USER ARM, FOAM SIMPLE 16.32 inch
BU-010	1001830-0000	1	GRIP: USER ARM, RIGHT, FOAM, FEATURED 22.5 INCH
BU-011	AK58-00245-2401	1	MEDALLION-ASSY: BUG, LIFE FITNESS, CHARCOAL GRAY

# Bullhorns

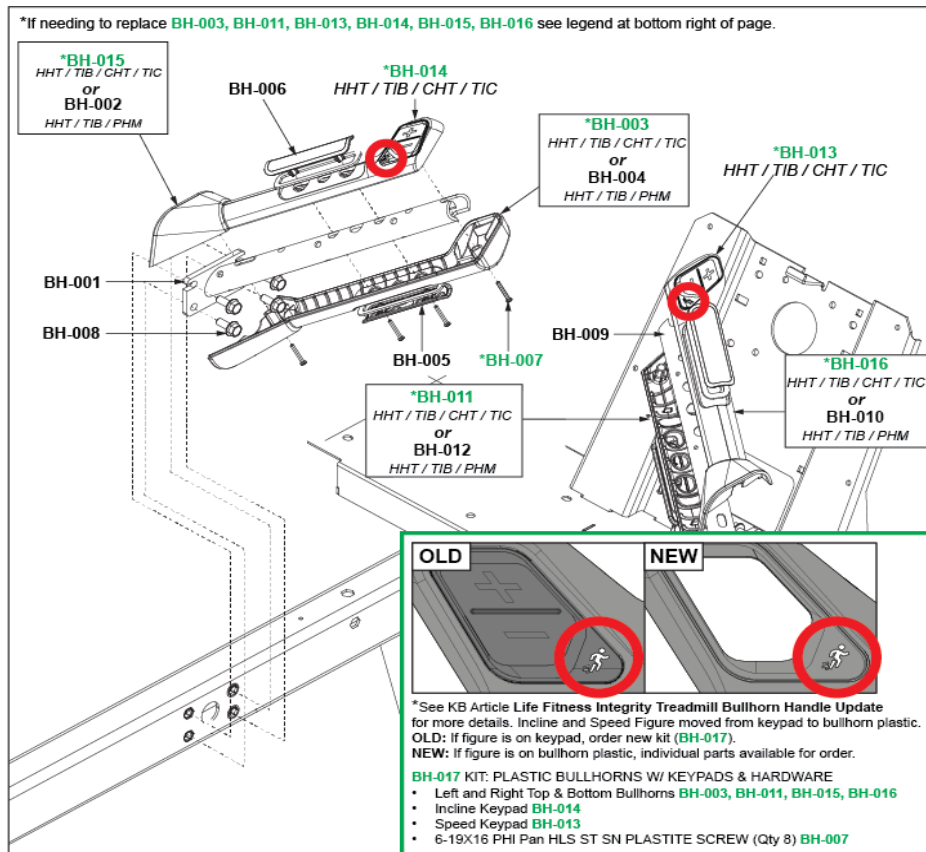

Ref #	Part Number	Qty	Description
BH-001	1001795-0001	1	WELDMENT: BULLHORN, LEFT
BH-002	1012066-0001	1	ASSEMBLY: BULLHORN SHROUD, TOP, LEFT, SIMPLE, CHARCOAL GRAY
BH-003	1012071-0001	1	ASSEMBLY: BULLHORN SHROUD, BOTTOM, LEFT, FEATURED, CHARCOAL GRAY
BH-004	1012069-0001	1	ASSEMBLY: BULLHORN SHROUD, BOTTOM, LEFT, SIMPLE, CHARCOAL GRAY
BH-005	AK69-00140-2404	2	ELECTRODE: INSERT-MOLDED ASSY, 4 INCH, BOTTOM, CHARCOAL GRAY
BH-006	AK69-00139-2404	2	ELECTRODE: INSERT-MOLDED ASSY, 4 INCH, TOP, CHARCOAL GARY
BH-007	0017-00101-2054	8	SCREW: 6-19 X 16, PHL, PAN, HLS, ST, ZN
BH-008	1005191-0001	8	SCREW: M8 X 1.25 6G6H X 20, UNS, HXW, CS, ST
BH-009	1001798-0001	1	WELDMENT: BULLHORN; RIGHT
BH-010	1012068-0001	1	ASSEMBLY: BULLHORN SHROUD, TOP, RIGHT, SIMPLE, CHARCOAL GRAY
BH-011	1012072-0001	1	ASSEMBLY: BULLHORN SHROUD, BOTTOM, RIGHT, FEATURED, CHARCOAL GRAY
BH-012	1012070-0001	1	ASSEMBLY: BULLHORN SHROUD, BOTTOM, RIGHT, SIMPLE, CHARCOAL GRAY
BH-013	1008489-0001	1	ASSEMBLY: USER RIGHT SPEED KEYPAD
BH-014	1008488-0001	1	ASSEMBLY: USER LEFT INCLINE KEYPAD

## Console Rear Shrouds

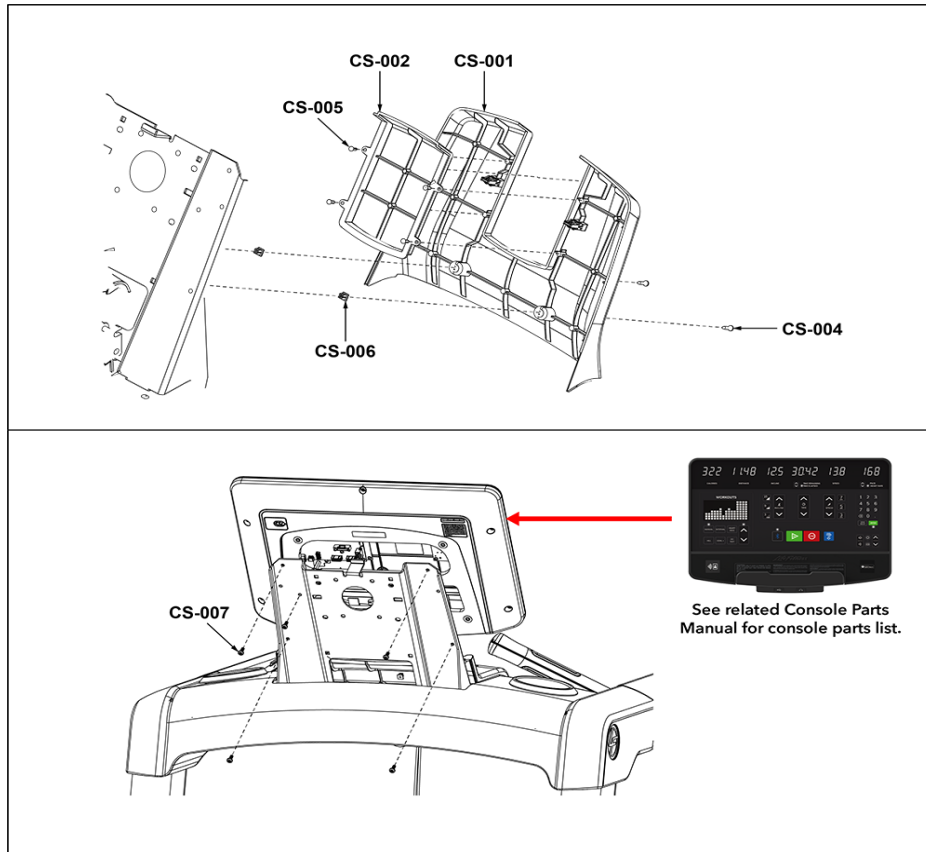

Ref #	Part Number	Qty	Description
CS-001	1001802-2400	1	SHROUD: CONSOLE, BACK, CHARCOAL GRAY
CS-002	1012986-0001	1	ASSEMBLY: SHROUD, CONSOLE BACK W/DECAL, PLANET
CS-004	0017-00101-1796	2	SCREW: M4.2 X 0.7 6G6G X 19, DIN, PHL, PAN, AB, ST, ZB
CS-005	0017-00101-1650	4	SCREW: 6-19 X 6, PHL, PAN, PLT, ST, ZB, VMI
CS-006	0017-00042-1147	2	GROMMET: SCREW, 8 OR 10
CS-007	0017-00101-1940	5	SCREW: M5 X 0.8 X 14, PHL, PAN, MS, ST, ZN

# Deck, Rails, and End Caps

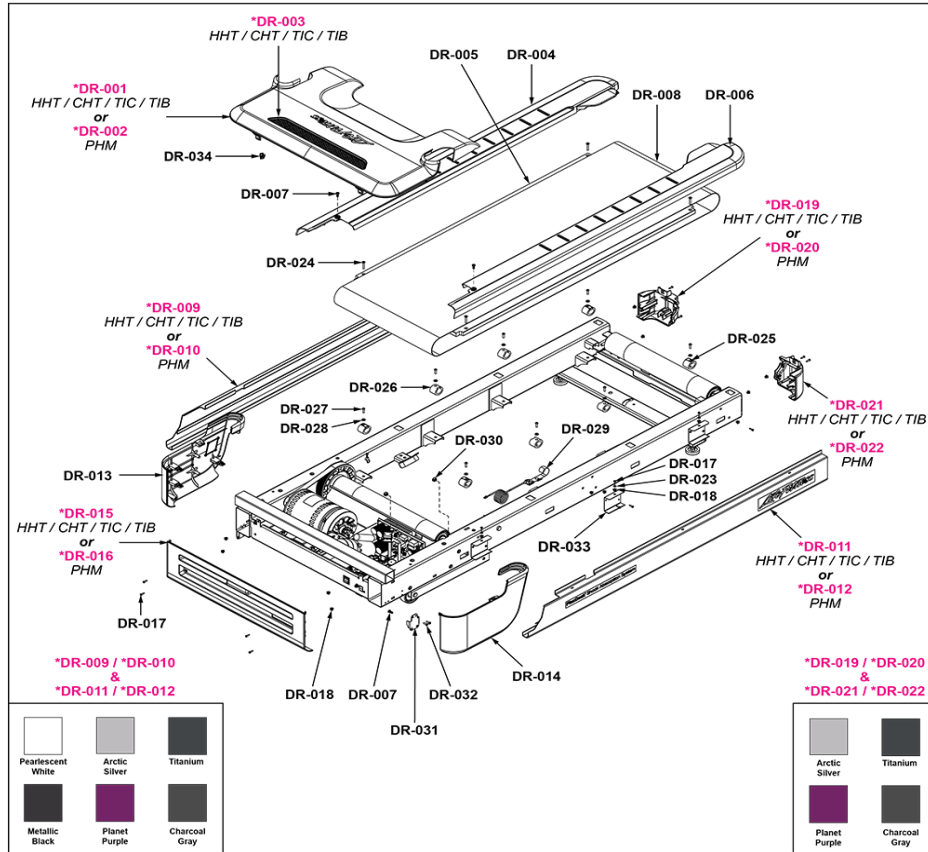

Ref #	Part Number	Qty	Description
DR-001	1001805-2400	1	SHROUD ASSY: MOTOR, TOP, CHARCOAL GRAY
DR-002	1012979-0001	1	ASSEMBLY: MOTOR SHROUD W/DECAL, TOP, PLANET
DR-003	1004595-0001	1	DECAL: SHROUD VENT
DR-004	1001924-2400	1	RAIL: TOP, USER, RIGHT, CHARCOAL GRAY
DR-005	1003817-0002	1	DECK: WALKING SURFACE, WITH WAX
DR-006	1001923-2400	1	RAIL: TOP, USER, LEFT, CHARCOAL GREY
DR-007	0017-00101-2138	4	SCREW: M6 X 1.0 X 16, DIN, PHL, PAN, MS, ST, ZB
DR-008	0K65-01002-0000	1	BELT: WALKING NP7131 21.5" WIDE
DR-009	1012994-0001	1	ASSEMBLY: SIDE RAIL W/DECAL, USER, RIGHT, FEATURED, TITANIUM
DR-009	1012990-0001	1	ASSEMBLY: SIDE RAIL W/DECAL, USER, RIGHT, FEATURED, ARCTIC SILVER
DR-009	1012988-0001	1	ASSEMBLY: CHARCOAL GRAY SIDE RAIL W/DECAL, USER, RIGHT, SIMPLE
DR-009	1012992-0001	1	ASSEMBLY: SIDE RAIL W/DECAL, USER, RIGHT, FEATURED, PEARL WHITE
DR-009	1012996-0001	1	ASSEMBLY: SIDE RAIL W/DECAL, USER, RIGHT, FEATURED, METALLIC BLACK
DR-010	1012981-0001	1	ASSEMBLY: SIDE RAIL W/DECAL, USER, RIGHT, PLANET
DR-011	1012987-0001	1	ASSEMBLY: CHARCOAL GRAY SIDE RAIL W/DECAL, USER, LEFT, SIMPLE

Ref #	Part Number	Qty	Description
DR-011	1012993-0001	1	ASSEMBLY: SIDE RAIL, USER, LEFT, FEATURED, TITANIUM
DR-011	1012989-0001	1	ASSEMBLY: SIDE RAIL W/DECAL, USER, LEFT, FEATURED, ARCTIC SILVER
DR-011	1012991-0001	1	ASSEMBLY: SIDE RAIL WDECAL, USER, LEFT, FEATURED, PEARL WHITE
DR-011	1012995-0001	1	ASSEMBLY: SIDE RAIL W/DECAL, USER, LEFT, FEATURED, METALLIC BLACK
DR-012	1012980-0001	1	ASSEMBLY: SIDE W/DECAL, USER, LEFT, PLANET
DR-013	1001807-2400	1	SHROUD ASSY: MOTOR, RIGHT, CHARCOAL GRAY
DR-014	1001808-2400	1	SHROUD ASSY: MOTOR, LEFT, CHARCOAL GRAY
DR-015	1001806-2400	1	SHROUD: MOTOR, FRONT, CHARCOAL GRAY
DR-016	1009217-0001	1	SHROUD ASSY: FRONT MOTOR SHROUD WITH BUMPERS
DR-017	0017-00101-1796	28	SCREW: M4.2 X 0.7 6G6G X 19, DIN, PHL, PAN, AB, ST, ZB
DR-018	0017-00042-1147	28	GROMMET: SCREW, 8 OR 10
DR-019	1001927-2400	1	ENDCAP: USER, RIGHT, SIMPLE, CHARCOAL GRAY
DR-019	1001928-0100	1	ENDCAP: USER, RIGHT, FEATURED, ARCTIC SILVER
DR-019	1001928-2200	1	ENDCAP: USER, RIGHT, FEATURED, TITANIUM
DR-020	1001928-0800	1	ENDCAP: USER, RIGHT, FEATURED, PURPLE
DR-021	1001926-2200	1	ENDCAP: USER LEFT, FEATURED, TITANIUM
DR-021	1001926-0100	1	ENDCAP: USER, LEFT, FEATURED, ARCTIC SILVER
DR-021	1001925-2400	1	ENDCAP: USER, LEFT, SIMPLE, CHARCOAL GRAY
DR-022	1001926-0800	1	ENDCAP: USER, LEFT, FEATURED, PURPLE
DR-023	1005472-0001	6	WASHER: M4.4 X 11 X 1, ST, ZN
DR-024	1000722-0001	4	SCREW: M6 X 1.0 X 35, FSHCS
DR-025	1001124-0001	4	NUT: U-CLIP, M6
DR-026	0K40-01026-0002	8	SPRING: TECSPAK, BLACK S/C-B
DR-027	1005212-0001	8	SCREW: M6 X 1 X 20, HEX, BUT, CS, ST, ZB
DR-028	0017-00104-0072	8	WASHER: 0.255 X 0.562 X 0.046, FLAT, ST, ZN
DR-029	AK58-00560-0000	1	SENSOR: STRIDE ASSEMBLY, UNIT
DR-030	0017-00042-0869	2	BUSHING: HOLE, PASS-THROUGH
DR-031	1010591-0001	2	BRACKET: SIDE SHROUD SUPPORT
DR-032	0017-00101-1986	4	SCREW: M5 X 0.8-6G6G X 16, DIN, PAN, TT, ST, ZN
DR-033	1018019-0001	6	BRACKET: SHROUD MTG
DR-034	1002263-0001	4	CLIP: M9.55 X 16.5, FASTENER, SPRING

## Drive Motor, Pulley, and Rollers

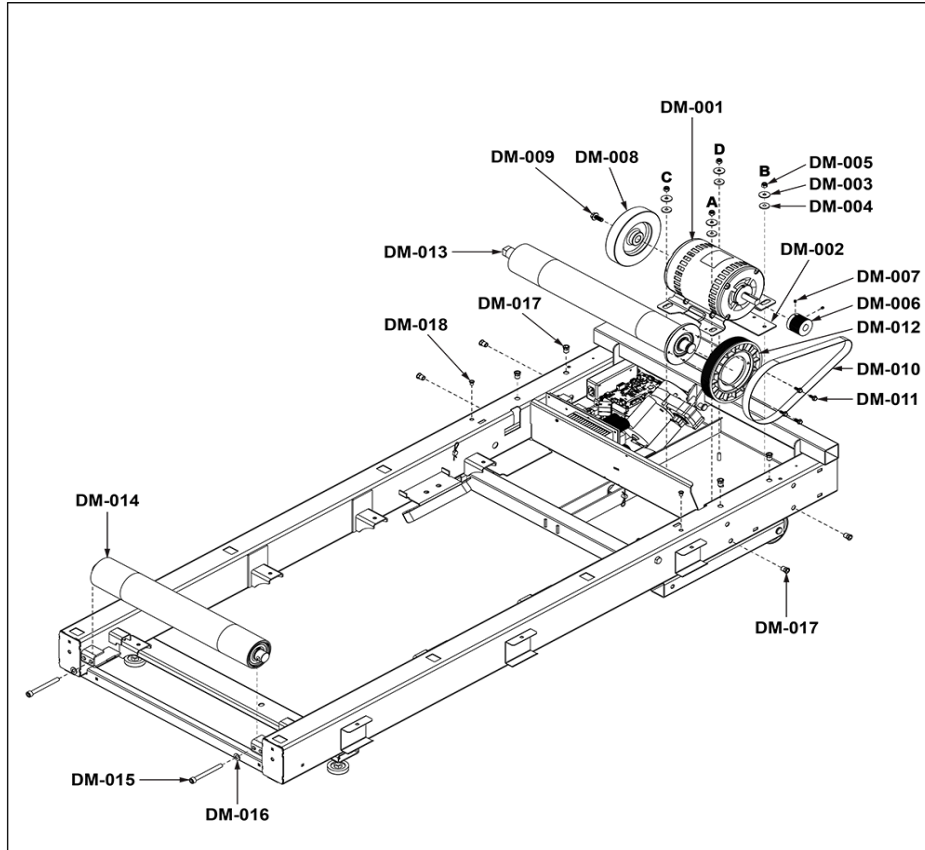

Ref #	Part Number	Qty	Description
DM-001	1002167-0000	1	MOTOR: AC, 4HP, INDUCTION
DM-002	0K58-01256-0001	2	PAD: INSULATING
DM-003	0017-00104-0409	4	WASHER: 0.327 X 1.125 X 0.090, FL, D, ST, BZ
DM-004	0K58-01255-0000	4	WASHER: INSULATING
DM-005	0017-00103-0333	4	NUT: M8 X 1.25-6H6H, DIN, LOCKING, ST, ZN
DM-006	1021771-0001	1	PULLEY: DRIVE
DM-007	1009209-0001	2	SCREW: M6 X 1 X 8, CUP POINT, SET SCREW
DM-008	0K65-01221-0000	1	FLYWHEEL: CAST IRON; WITH INTEGRAL FAN
DM-009	1005547-0001	1	SCREW: M10 X 1.50 6G6H X 25, UNS, FLG, CS, ST, ZB, W/PATCH
DM-010	1004417-0001	1	BELT: DRIVE
DM-011	1005249-0001	4	SCREW: M6 X 1 X 16, DIN, UNS, HXW, SERRATED, CS, ST, ZB
DM-012	1002171-0001	1	PULLEY: ROLLER
DM-013	1000841-0002	1	ROLLER: FRONT, 3.5" DIA
DM-014	1001382-0002	1	ROLLER: REAR, 3.5" DIA
DM-015	1009113-0001	2	SCREW: M10 X 1.5 X 80, SHCS
DM-016	0017-00104-0470	2	WASHER: M10.5 X 20 X 2, DIN, DFLAT, ST, ZB
DM-017	0017-00009-1191	1	INSERT: M8 X 6.6, THREADED, HEX
DM-018	0017-00009-1259	1	INSERT: M6 X 5, THREADED, HEX

# Lift Frame, Leg Levelers, and Wheels (HHT, CHT, TIC, TIB)

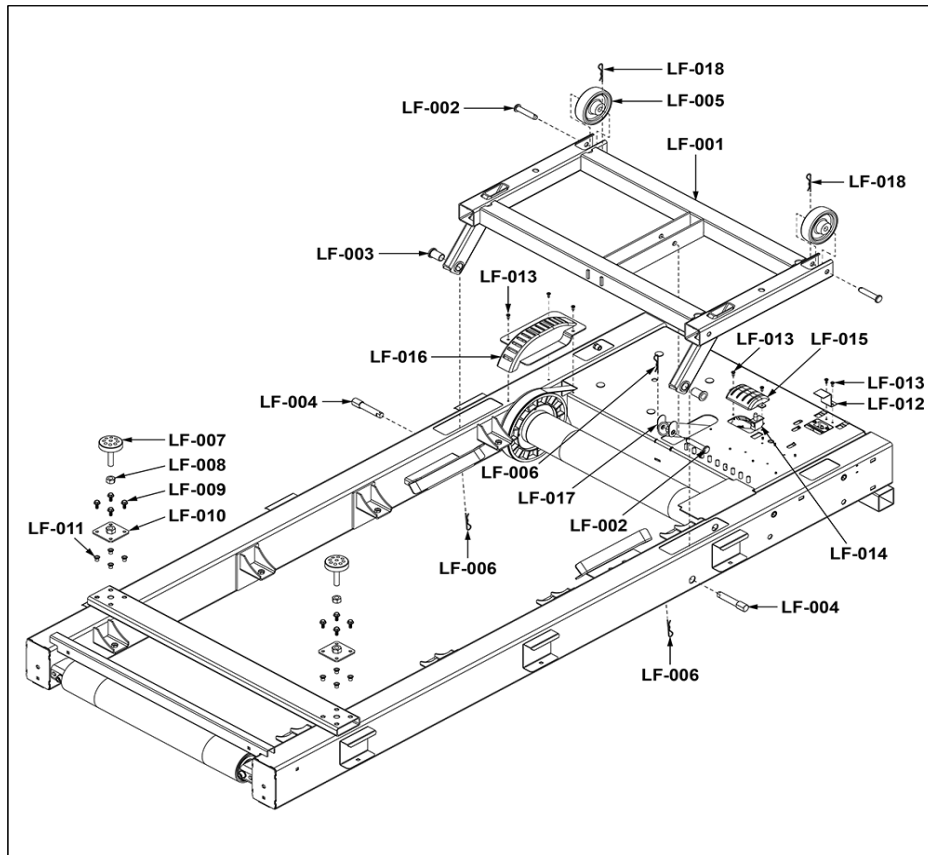

Ref #	Part Number	Qty	Description
LF-001	1000846-0700	1	FRAME: LIFT; PAINTED
LF-002	1002162-0001	3	PIN: M12 X 60, CLEVIS, ST
LF-003	1001396-0001	2	BEARING: FLG SLV
LF-004	1000840-0000	2	SHAFT: LIFT FRAME, PIVOT
LF-005	1001387-0001	2	WHEEL: LIFT FRAME
LF-006	1004469-0001	3	PIN: M10 X 50, COTTER
LF-007	1001956-0001	2	LEVELER: BASE FRAME
LF-008	1003534-0001	2	NUT: M12 X 1.75, HEX
LF-009	1005249-0001	8	SCREW: M6 X 1 X 16, DIN, UNS, HXW, SERRATED, CS, ST, ZB
LF-010	1002793-0001	2	PLATE: LEVELER MTG.
LF-011	0017-00009-1259	8	INSERT: M6 X 5, THREADED, HEX
LF-012	1004354-0001	1	BRACKET: CABLE SUPPORT
LF-013	0017-00101-1968	7	SCREW: M4 X 0.7 X 10, PHL, PAN, TT, ST, ZS
LF-014	0017-00032-0195	1	SWITCH: MOMENTARY ACTION
LF-015	1003252-0001	1	COVER: ACTUATOR, BOTTOM
LF-016	1002721-0001	1	COVER: PULLEY, ROLLER
LF-017	1001392-0001	2	WASHER: EZ GRIP
LF-018	HP016820	2	COTTER PIN .125 X 1.25

## Lift Frame, Leg Levelers, and Wheels (PHM)

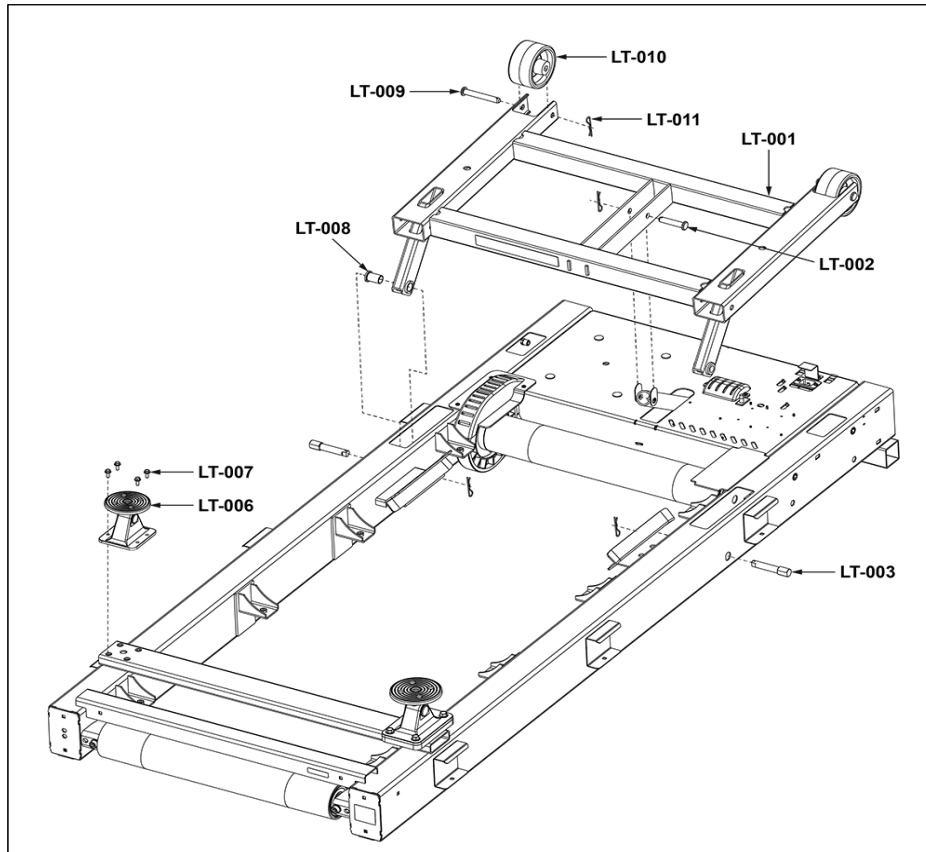

Ref #	Part Number	Qty	Description
LT-001	1008251-0001	1	FRAME: LIFT, PLANET UNPAINTED
LT-002	1002162-0001	1	PIN: M12 X 60, CLEVIS, ST
LT-003	1000840-0000	2	SHAFT: LIFT FRAME, PIVOT
LT-006	1010930-0001	2	ASSEMBLY: PLANET FITNESS, LEG, LEVELER
LT-007	1005249-0001	8	SCREW: M6 X 1 X 16, DIN, UNS, HXW, SERRATED, CS, ST, ZB
LT-008	1001396-0001	2	BEARING: FLG SLV
LT-009	1008284-0001	2	PIN: M12, CLEVIS
LT-010	1008183-0001	2	WHEEL: LIFT
LT-011	1004469-0001	5	PIN: M10 X 50, COTTER

# Lower Base Wiring Diagram

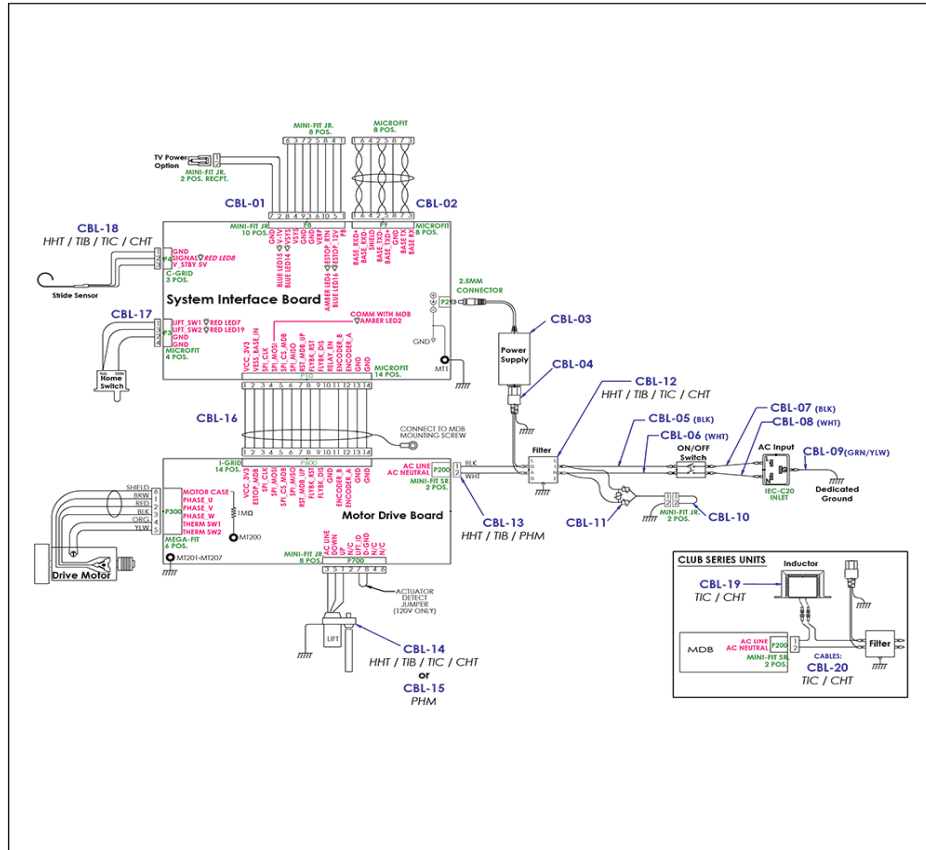

Ref #	Part Number	Qty	Description
CBL-01	1015794-0004	1	CABLE: MCFLY TREAD, CONSOLE TO BASE, POWER
CBL-02	1002239-0004	1	CABLE: CONSOLE TO BASE, SIGNAL, 2040MM
CBL-03	1011106-0001	2	POWER SUPPLY: 24VDC, 5A
CBL-04	1004563-0001	1	CABLE: LINE FILTER TO POWER SUPPLY
CBL-05	1004044-0002	1	CABLE: SWITCH TO FILTER, BLACK
CBL-06	1004044-0001	1	CABLE: SWITCH TO FILTER, WHITE
CBL-07	1004046-0002	1	CABLE: POWER INPUT, BLACK, 125MM
CBL-08	1004046-0001	1	CABLE: POWER INPUT, WHITE, 125MM
CBL-09	1004201-0001	1	CABLE: GROUND
CBL-10	AK58-00263-0000	1	CABLE ASSY: HI-POT, JUMPER
CBL-11	AK58-00224-0001	1	CABLE ASSY: MOV, FILTER
CBL-12	1008383-0001	1	FILTER: LINE, 10A, HI-VOLT CONSUMER
CBL-12	0017-00003-1015	1	FILTER: LINE, 20A, 250VAC
CBL-13	1004045-0002	1	CABLE: POWER INPUT, 400 mm
CBL-14	1001013-0002	1	ACTUATOR: LINEAR, 230V
CBL-14	1001013-0001	1	ACTUATOR: LINEAR, 115V
CBL-15	1001013-0003	1	ACTUATOR: LINEAR, 115V
CBL-15	1001013-0004	1	ACTUATOR: LINEAR, 230V
CBL-16	1004243-0001	1	CABLE: SIB-MDB
CBL-17	AK58-00027-0000	1	CABLE ASSY: ZERO HOME SWITCH
CBL-18	AK58-00560-0000	1	SENSOR: STRIDE ASSEMBLY, UNIT
CBL-19	111E-00001-0042	1	INDUCTOR: 15MH; 230V 2-SHTS-C

<b>Ref #</b>	<b>Part Number</b>	<b>Qty</b>	<b>Description</b>
CBL-19	111E-00001-0041	1	INDUCTOR: 3MH, 120VAC, T9I
CBL-20	1006002-0001	1	CABLE ASSY: POWER, 230V, PCST
CBL-20	1006003-0001	1	CABLE ASSY: POWER, 120V, PCST

## Power Cords

LC-001			96", 244 cm
LC-002			144", 366 cm
LC-003			96", 244 cm
LC-004			102", 260 cm
LC-005			144", 366 cm
LC-006			144", 366 cm
LC-007			144", 366 cm
LC-008			144", 366 cm
LC-009			144", 366 cm
*LC-010 CHT / TIC			144", 366 cm

Ref #	Part Number	Qty	Description
LC-001	0017-00003-0978	1	LINE-CORD: R/A; NEMA 5-20 96" S/C-C
LC-002	0017-00003-0980	1	LINE-CORD: R/A; NEMA 5-20 144 IN. S/C-C
LC-003	0017-00003-0974	1	LINE-CORD: 96"; W/RECP S/C-C
LC-004	0017-00003-0781	1	LINE-CORD: R/A; 220V; USA D
LC-005	0017-00003-0696	1	LINE-CORD: R/A; CEE7; 103" 10A 250V D
LC-006	0017-00003-0890	1	LINE-CORD: U.K; R/A D
LC-007	0017-00003-0996	1	LINE-CORD: IEC; AUSTRALIAN; 230/50 C
LC-008	0017-00003-1054	1	LINE-CORD: BRAZIL, IEC-C19
LC-009	0017-00003-1068	1	LINE-CORD: ARGENTINA, IRAM 2073, IEC-C19
LC-010	0017-00003-1079	1	LINECORD NEMA 5-15P WITH R/A C-19 CONNECTOR

## Service Wheel (HHT and TIB)

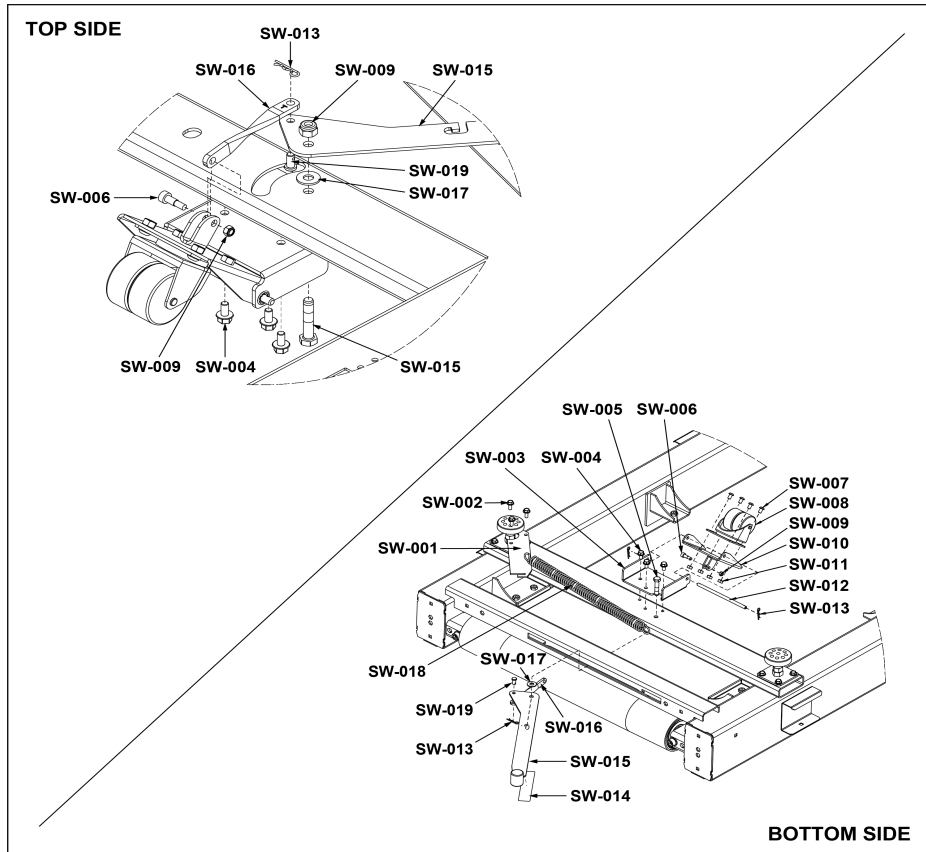

Ref #	Part Number	Qty	Description
SW-001	1008944-0001	1	BRACKET: SPRING
SW-002	1005249-0001	3	SCREW: M6 X 1 X 16, DIN, UNS, HXW, SERRATED, CS, ST, ZB
SW-003	1003600-0001	1	BRACKET: BOTTOM PIVOT, SERVICE WHEEL
SW-004	1009565-0001	3	BOLT: M6 X 1.0 X 12, TAPTITE
SW-005	0017-00101-1925	1	M8.0X1.25-6G6GX40. DIN UNS HEX MS ST ZN
SW-006	1006044-0001	1	SCREW: M5 X 0.8, 6MM DIA SHOULDER
SW-007	1006331-0001	4	SCREW: M6 X 1.0 X 10, HXS, BUT, CS, ST, BZ
SW-008	CW-25006	1	CASTOR: SWIVEL, SERVICE WHEEL
SW-009	1006046-0001	1	NUT: M5 NYLOCK
SW-010	1006042-0001	1	WELDMENT: WHEEL MOUNT
SW-011	0017-00103-0360	4	NUT: M6 X 1.0, HEX, ST, ZS
SW-012	1003609-0001	1	PIN: PIVOT, SERVICE WHEEL
SW-013	1010579-0001	3	PIN: M6 X 28.6, COTTER
SW-014	1009126-0001	1	DECAL: PROTECTIVE, LEVER
SW-015	1003598-0000	1	WELDMENT: LEVER, SERVICE WHEEL
SW-016	1003613-0001	1	LINK: TWIST, SERVICE WHEEL
SW-017	0017-00104-0510	1	WASHER: M8.4 X 19 X 1.6, DIN, FLAT, ST, ZB
SW-018	1009037-0001	1	SPRING: EXTENSION, 7.75 X 0.875 OD
SW-019	1010578-0001	1	PIN: M6.35 X 12.7, CLEVIS

# Upper Base with Integrity SL and Discover SE4 Consoles Wiring

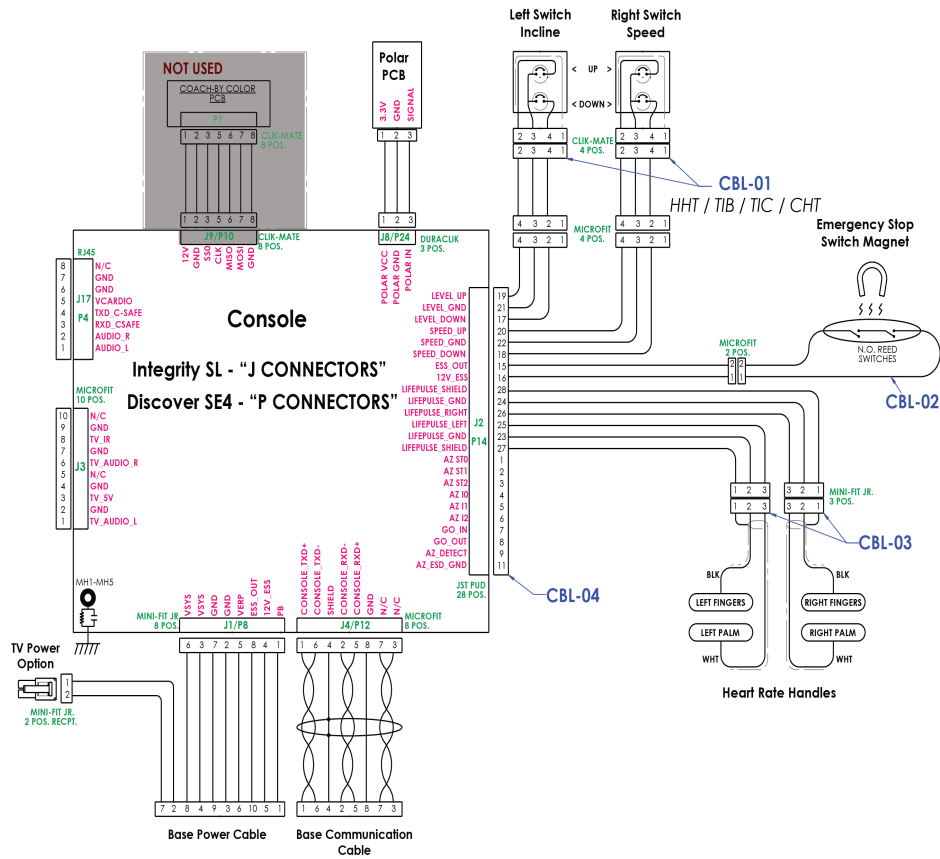

Ref #	Part Number	Qty	Description
CBL-01	1003835-0001	1	CABLE: KEYPAD, EXTENSION
CBL-02	AK58-00036-0000	1	CABLE ASSY: EMERGENCY STOP, SWITCH ASSY.
CBL-03	1003871-0001	1	CABLE: LIFEPULSE ELECTRODES, 795MM
CBL-04	1014575-0000	1	CABLE: MCFLY TREAD, BASE INTERFACE

