

Symbio Runner Smooth Charcoal Base

EVT-EV24-CGCXE-01

Parts Manual

5/6/2025 11:47:07 AM



LifeFitness
WHAT WE LIVE FOR

Table of Contents

Actuator	3
A Legend Description	4
Base Frame Electronics	5
Base Wiring Diagram	7
Bridge and Bridge Shrouds	9
Console Mount and Console Rear Shroud	11
Console Tablet Board External Connections	12
Control Panel, Bullhorns and E-STOP	13
Deck Stiffness and Running Metrics	15
Deck, Motor and Rollers	17
Hardware Kit	18
Left Upright	19
Leveling Feet	21
Lift Frame and Com Port	22
Power Cords	24
Right Upright	25
Service Wheel	27
Side Shrouds	28
Top Steps	30
Upper Assembly Wiring Diagram	31

Actuator

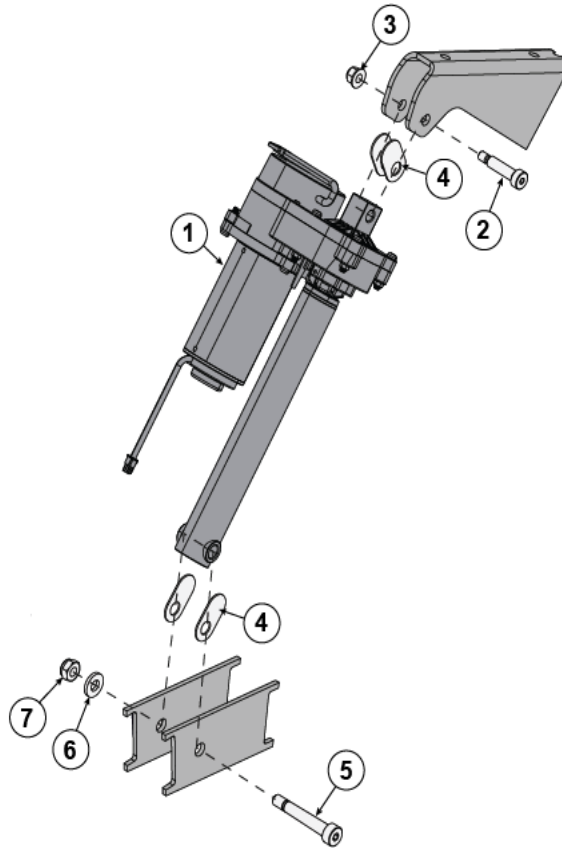

Ref #	Part Number	Qty	Description
1	1016914-0001	1	ACTUATOR: LINEAR
2	1025073-0001	1	SCREW: M8 X 1.25 X 35, 10MM DIA, SHL
3	1003388-0001	1	NUT: M8 X 1.25-6H, DIN, UNF, HEX, LOCKNUT
4	1001392-0001	4	WASHER: EZ GRIP
5	1026816-0001	1	SCREW: M10 X 1.50 X 55, 12MM DIA, SHL
6	0017-00104-0263	1	WASHER: 0.406 X 0.875 X 0.125, FL, ST
7	0017-00103-0334	1	NUT: M10 X 1.50-6H6H, DIN, LOCKNUT, ST, ZB

A Legend Description

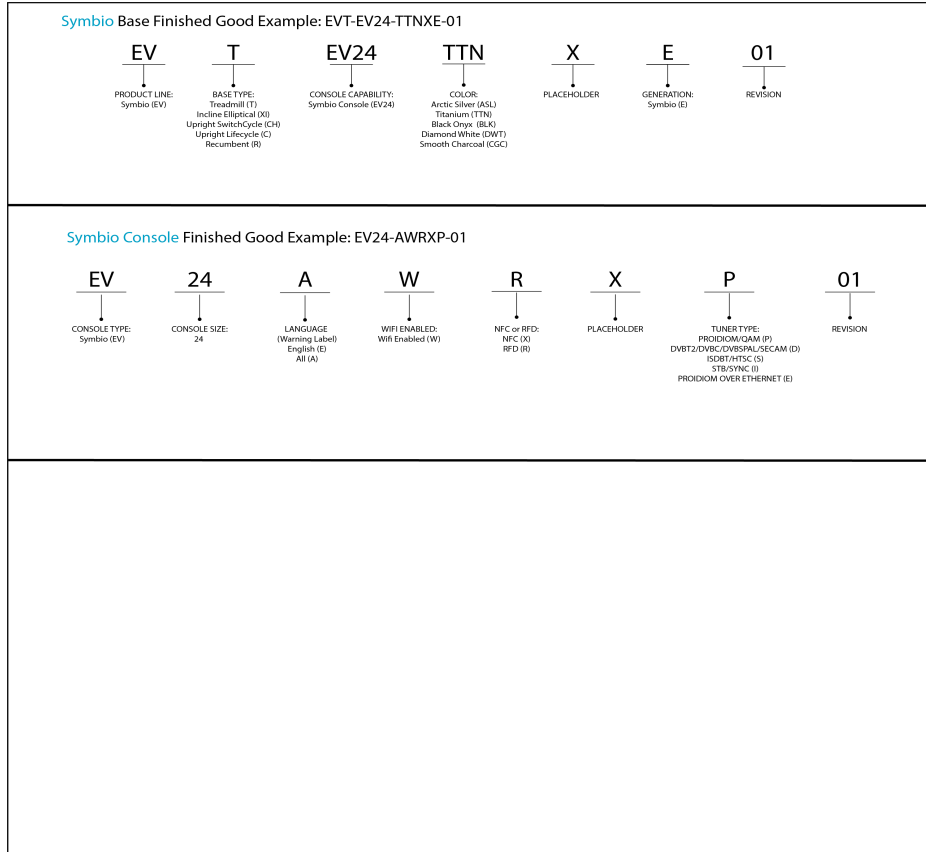

Ref #	Part Number	Qty	Description
-	LEGEND_DESCRIPTION	1	LEGEND DESCRIPTION

Base Frame Electronics

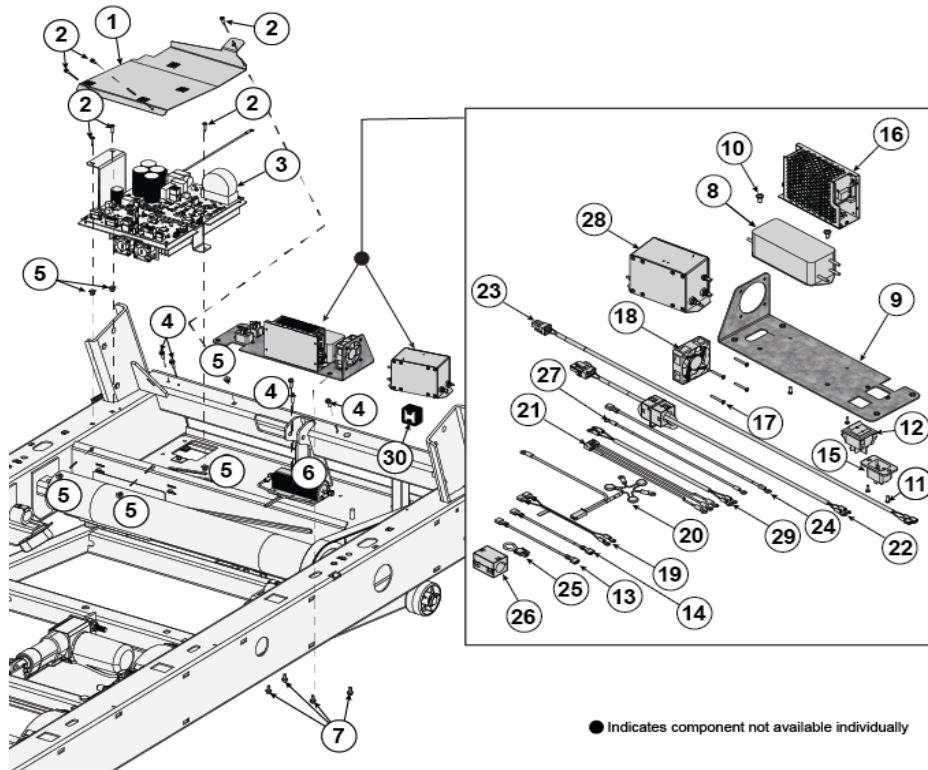

Ref #	Part Number	Qty	Description
1	1020291-0001	1	ASSEMBLY: PTC COVER, FOAM PAD
2	0017-00101-1796	6	SCREW: M4.2 X 0.7 6G6G X 19, DIN, PHL, PAN, AB, ST, ZB
3	1018090-0001	1	ASSEMBLY: PTC BOARD, HEAT SINK
4	0017-00101-1961	7	SCREW: M5 X 0.8 X 16, SLT, HXF, TT, ST, ZS
5	0017-00042-1147	6	GROMMET: SCREW, 8 OR 10
6	1023193-0001	1	RESISTOR ASSY: 250W, 100 OHM, 5%, M6 STUDS
7	0017-00101-2151	4	SCREW: M5 X 0.8 6G6G X 12, FLANGE, HEAD, CS, G5, CD
8	1010290-0001	1	FILTER: LINE, 25A, 250VAC
9	1018206-0001	1	SHEET METAL: POWER INTAKE BRACKET
10	1018223-0001	2	SCREW: M5 X 0.8-6H6H X 10, PHL, PAN, CS, ST.
11	1018229-0001	4	SCREW: M3 X 0.5-6H6H X 10, PHL, PAN, CS, ST.
12	0017-00032-0198	1	SWITCH: POWER, DPST ROCKER
13	1004046-0002	1	CABLE: POWER INPUT, BLACK, 125MM
14	1004046-0001	1	CABLE: POWER INPUT, WHITE, 125MM
15	0017-00003-0949	1	RECEPTACLE: IEC, SIDE, FLANGE
16	1019393-0001	1	POWER SUPPLY: 24V, 250-300W
17	1018311-0001	4	SCREW: M3 X 0.5-6H6H X 25, PHL, PAN, CS, ST.
18	1019626-0001	1	FAN: 60MM X 60MM X 20MM, 24VDC
19	1020541-0001	1	CABLE ASSY: ON-OFF SWITCH TO FILTER
20	1020540-0001	1	CABLE ASSY: MOV, FILTER

Ref #	Part Number	Qty	Description
21	1020824-0001	1	CABLE ASSY: POWER SUPPLY, LINE FILTER
22	1020613-0001	1	CABLE ASSY: FILTER TO AC LINE
23	1020542-0001	1	CABLE ASSY: POWER SUPPLY TO PTC
24	1004201-0001	1	CABLE: GROUND
25	AK58-00263-0000	1	CABLE ASSY: HI-POT, JUMPER
26	121E-00001-0023	1	FERRITE: SUPPRESSION, CORE-CASE
27	1021514-0002	1	CABLE: GROUND, 250MM
28	1023531-0001	1	FILTER: DIFFERENTIAL MODE, 25A, 250VAC
29	1023826-0001	1	CABLE ASSY: LINE FILTER TO DIFFERENTIAL FILTER
30	1024486-0001	1	FERRITE-BEAD: SUPPRESSION, 225OHM-100MHz

Base Wiring Diagram

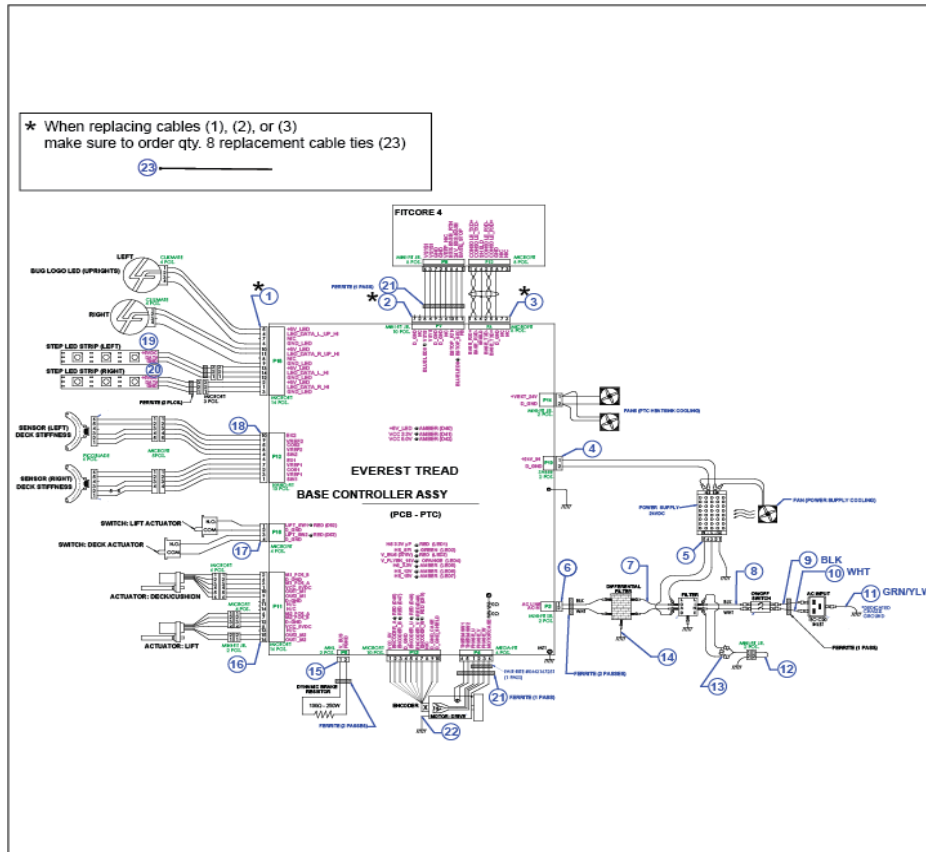

Ref #	Part Number	Qty	Description
1	1020644-0001	1	CABLE ASSY: DECK LIGHTING
2	1021196-0004	1	CABLE ASSY: CONSOLE TO BASE, POWER, TREAD
3	1020718-0004	1	CABLE: BASE CONSOLE COMM, 2040MM
4	1020542-0001	1	CABLE ASSY: POWER SUPPLY TO PTC
5	1020824-0001	1	CABLE ASSY: POWER SUPPLY, LINE FILTER
6	1020613-0001	1	CABLE ASSY: FILTER TO AC LINE
7	1023826-0001	1	CABLE ASSY: LINE FILTER TO DIFFERENTIAL FILTER
8	1020541-0001	1	CABLE ASSY: ON-OFF SWITCH TO FILTER
9	1004046-0002	1	CABLE: POWER INPUT, BLACK, 125MM
10	1004046-0001	1	CABLE: POWER INPUT, WHITE, 125MM
11	1004201-0001	1	CABLE: GROUND
12	AK58-00263-0000	1	CABLE ASSY: HI-POT, JUMPER
13	1020540-0001	1	CABLE ASSY: MOV, FILTER
14	1021514-0002	1	CABLE: GROUND, 250MM
15	1023193-0001	1	RESISTOR ASSY: 250W, 100 OHM, 5%, M6 STUDS
16	1020539-0001	1	CABLE ASSY: ACTUATOR CUSHION-LIFT
17	1020543-0001	1	CABLE ASSY: ZERO HOME SWITCH
18	1020823-0001	1	CABLE ASSY: PTC, RUNNING METRICS
19	1020631-0002	1	CABLE ASSY: LED STRIP, TOP STEP, LEFT
20	1020631-0001	1	CABLE ASSY: LED STRIP, TOP STEP, RIGHT
21	121E-00001-0010	2	FERRITE-BEAD: SUPPRESSION B
22	1022724-0001	1	CABLE: GROUND, 155MM

Ref #	Part Number	Qty	Description
23	0017-00042-0772	8	CABLE TIE: L-15.000 INCH

Bridge and Bridge Shrouds

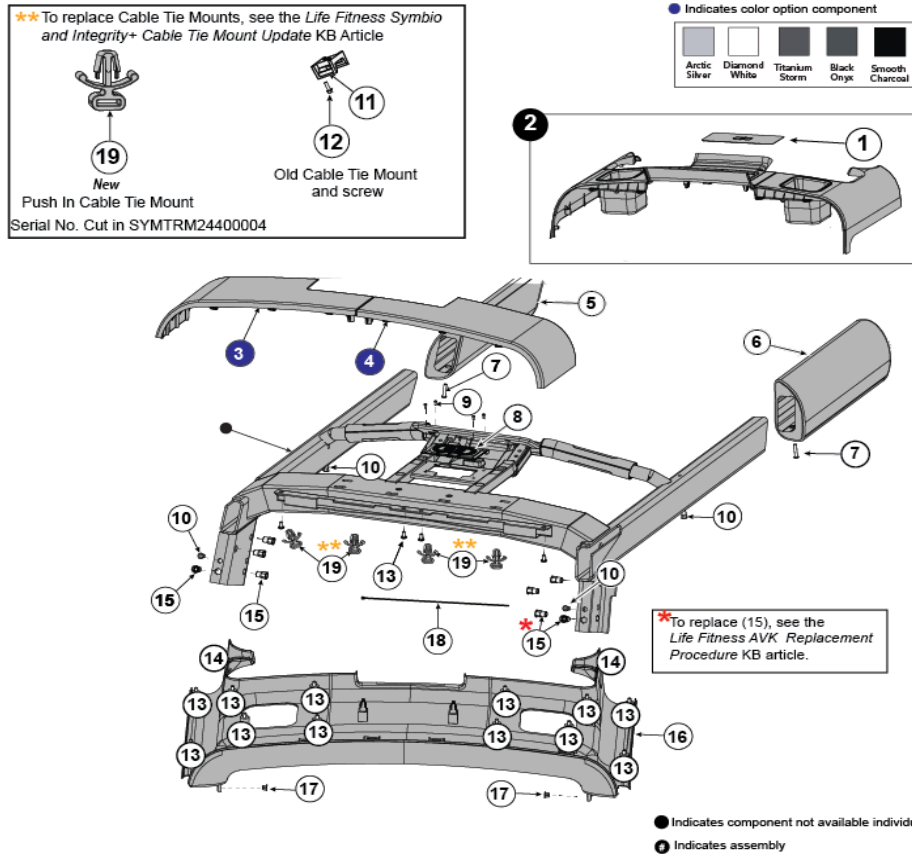

Ref #	Part Number	Qty	Description
1	1018872-0001	1	PAD ASSY: WIRELESS CHARGER, ADHESIVE
2	1025551-0001	1	ASSEMBLY: TOP BRIDGE SHROUD, W/CHARGING PAD
3a	1020424-0101	1	CASTING ASSY: BRIDGE, TOP, RIGHT, ARCTIC SILVER
3b	1020424-2101	1	CASTING ASSY: BRIDGE, TOP, RIGHT, PEARLESENT WHITE
3d	1020424-2301	1	CASTING ASSY: BRIDGE, TOP, RIGHT, BLACK ONYX
3c	1020424-2201	1	CASTING ASSY: BRIDGE, TOP, RIGHT, TITANIUM
3e	1020424-2601	1	CASTING ASSY: BRIDGE, TOP, RIGHT, SMOOTH CHAR GRAY
4c	1020429-2201	1	CASTING ASSY: BRIDGE, TOP, LEFT, TITANIUM
4e	1020429-2601	1	CASTING ASSY: BRIDGE, TOP, LEFT, SMOOTH CHAR GRAY
4d	1020429-2301	1	CASTING ASSY: BRIDGE, TOP, LEFT, BLACK ONYX
4a	1020429-0101	1	CASTING ASSY: BRIDGE, TOP, LEFT, ARCTIC SILVER
4b	1020429-2101	1	CASTING ASSY: BRIDGE, TOP, LEFT, PEARLESENT WHITE
5	1018844-0001	1	ARM: USER, RIGHT
6	1018846-0001	1	ARM: USER, LEFT
7	1018757-0001	2	SCREW: M6 X 1 X 30, HXS, SOC, BLT, CS
8	1011883-0001	1	PCB ASSY: SE4, WIRELESS CHARGER
9	1015870-0001	4	SCREW: M3 X.5 X8, PHL, PAN, ST, BZ
10	0017-00009-1358	4	INSERT: M6 X 6.6, THREADED, HEX

Ref #	Part Number	Qty	Description
11	1019763-0001	4	MOUNT: CABLE TIE
12	0017-00101-1961	4	SCREW: M5 X 0.8 X 16, SLT, HXF, TT, ST, ZS
13	1022792-0001	16	SCREW: M6 X 1.00-6G6G X 12, DIN, PHL, PAN, MS, ST
14	1017559-0001	2	SCREW: M4 X 0.7 X 10, PHL, PH, ST, BZ
15	1019826-0001	8	INSERT: M8 X 7.9, THREADED, HEX
16	1018850-0001	1	SHROUD ASSY: BRIDGE, BOTTOM
17	0017-00042-1147	2	GROMMET: SCREW, 8 OR 10
18	0017-00042-0772	4	CABLE TIE: L-15.000 INCH
19	1026190-0001	4	CABLE TIE: MOUNT, WING

Console Mount and Console Rear Shroud

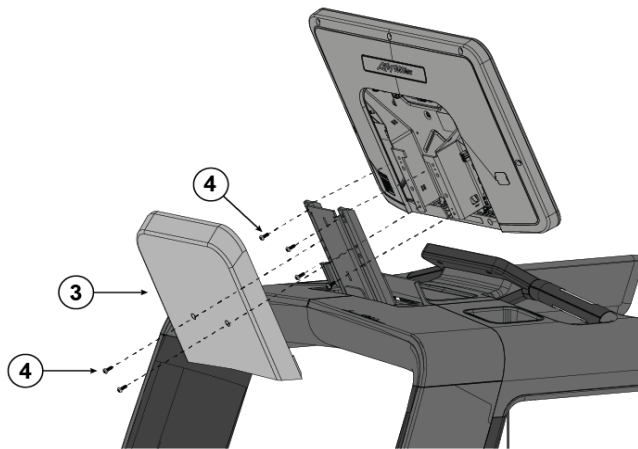
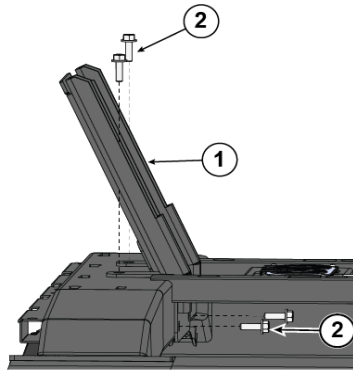

Ref #	Part Number	Qty	Description
1	1018490-0701	1	WELDMENT: CONSOLE MOUNT, TREADMILL, BLACK
2	1021782-0001	4	SCREW: M6 X 1-6G6G X 20, HXS, HXF, FHB, ST
3	1018852-0001	1	SHROUD ASSY: CONSOLE REAR
4	0017-00101-1972	6	SCREW: M5 X 0.8 X 14, PHL, PAN, MS, ST, BZ
5	0017-00101-1961	2	SCREW: M5 X 0.8 X 16, SLT, HXF, TT, ST, ZS
6	1006261-0001	2	CABLE: GROUNDING BRAID

Console Tablet Board External Connections

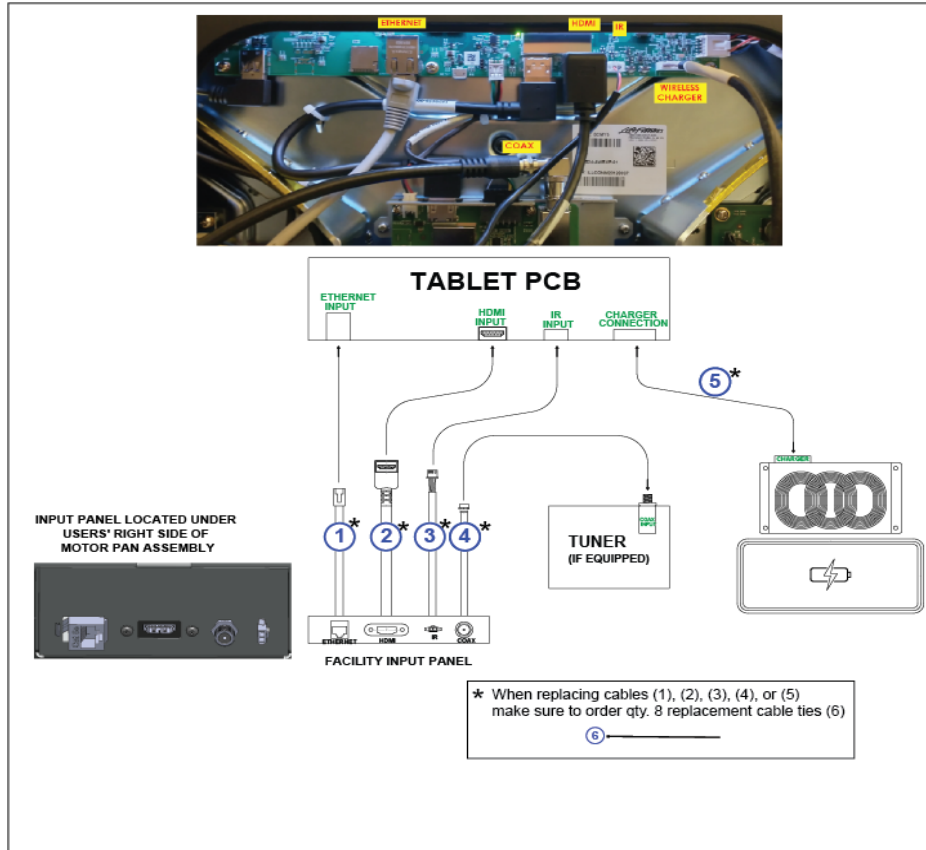

Ref #	Part Number	Qty	Description
1	AK70-00092-0000	1	CABLE ASSY: CAT5E, V2, 84 INCH
2	1001653-0005	1	CABLE ASSY: HDMI, PANEL MOUNT, RIGHT, 1900MM
3	1001671-0006	1	CABLE: IR, CONSOLE TO PANEL, 1900MM
4	AK65-00062-0000	1	CABLE ASSY: COAX, RG6
5	1014289-0001	1	CABLE ASSY: WIRELESS CHARGER, 12V & UART
6	0017-00042-0772	8	CABLE TIE: L-15.000 INCH

Control Panel, Bullhorns and E-STOP

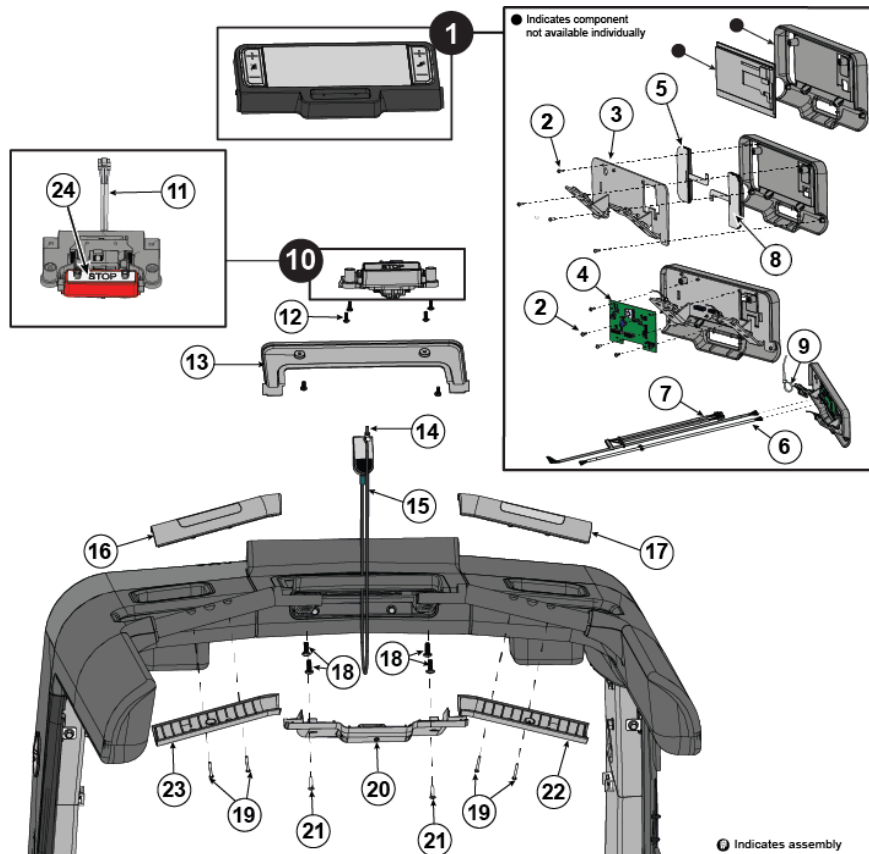

Ref #	Part Number	Qty	Description
1	1019454-0001	1	CONSOLE: TREAD CENTER
2	1015870-0001	8	SCREW: M3 X.5 X8, PHL, PAN, ST, BZ
3	1019463-0001	1	BRACKET: CENTER CONSOLE
4	1019397-0011	1	MAIN PCB ASSY: EVEREST CENTER CONSOLE
5	1019290-0002	1	KEYPAD: CENTER CONSOLE, SPEED, RIGHT
6	1019715-0001	1	CABLE ASSY: MIPI
7	1020081-0001	1	CABLE ASSY: ELSE & LP
8	1019290-0001	1	KEYPAD: CENTER CONSOLE, INCLINE, LEFT
9	0017-00042-0622	2	CABLE TIE: 3-7/8 INCH, S/C-09-B
10	1020089-0001	1	ASSEMBLY: E-STOP, TREADMILL
11	1020574-0001	1	CABLE ASSY: LIMIT SWITCH TO SIB
12	1017559-0001	6	SCREW: M4 X 0.7 X 10, PHL, PH, ST, BZ
13	1020113-0001	1	SHROUD: CENTER CONSOLE, REAR
14	1010103-0001	1	SCREW: M4 X 1.79 X 10, PHL, PAN, PLT, ST, ZC
15	1020787-0001	1	ASSEMBLY: TETHER, E-STOP
16	1018856-0001	1	SHROUD ASSY: ERGO BAR, TOP, LEFT
17	1018854-0001	1	SHROUD ASSY: ERGO BAR, TOP, RIGHT
18	0017-00101-2138	4	SCREW: M6 X 1.0 X 16, DIN, PHL, PAN, MS, ST, ZB
19	1025992-0001	4	SCREW: M3 X 0.5 X 12, HXS, CS, ST
20	1019655-0001	1	SHROUD: CENTER CONSOLE, BOTTOM
21	1011849-0001	2	SCREW: M4 X 0.7 X 16, PHL, RND, ST, ZC
22	1018858-0001	1	SHROUD ASSY: ERGO BAR, BOTTOM, RIGHT

Ref #	Part Number	Qty	Description
23	1018860-0001	1	SHROUD ASSY: ERGO BAR, BOTTOM, LEFT
24	1020261-0001	1	DECAL: E-STOP BUTTON

Deck Stiffness and Running Metrics

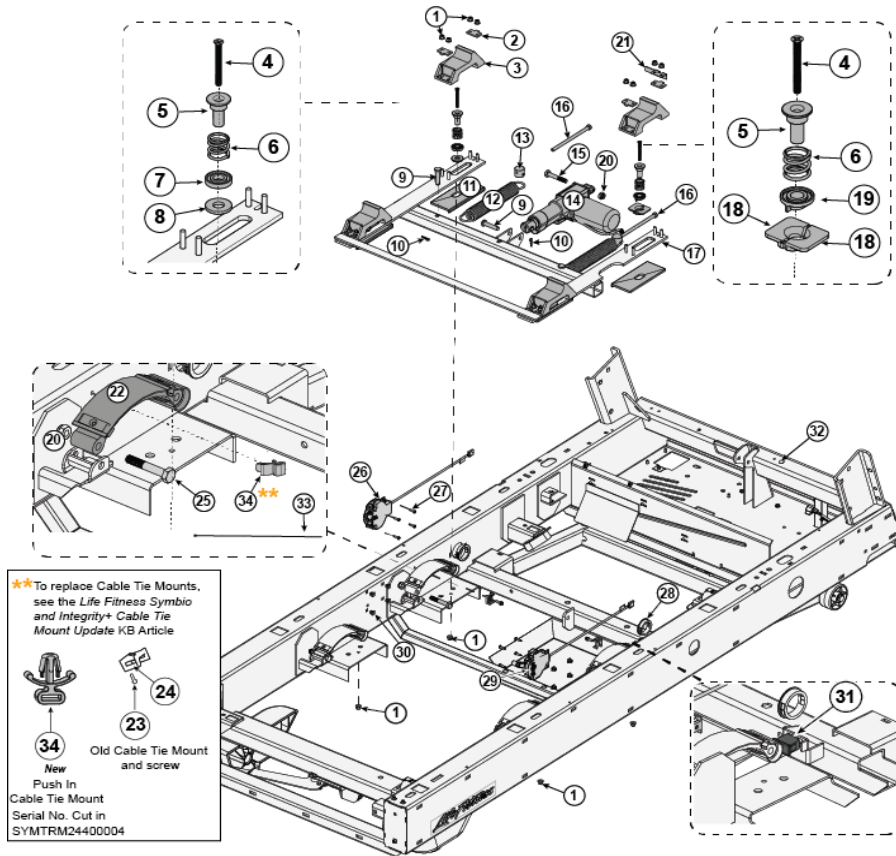

Ref #	Part Number	Qty	Description
1	1012634-0001	20	NUT: M6X1-6H, DIN, LOCK, ST, ZC
2	1021033-0001	8	PLATE: BACKING
3	1021098-0001	4	BRACKET: STOP, MOLDED
4	1025723-0001	4	SCREW: M6 X 1.0-6G X 60, HKA, FLT, CS, ST
5	1022447-0001	4	BUSHING: DECK STIFFNESS RETENTION
6	1022597-0001	4	SPRING: COMPRESSION, DECK STIFFNESS
7	1022507-0001	2	BUSHING: M12.2 X 30.5, RETENTION, SPRING
8	1022506-0001	2	BUSHING: M12.5 X 30.5 X 4, FLAT, FRAME GUIDE
9	1016706-0001	3	PIN: M10 X 46, CLEVIS, ST
10	1010579-0001	2	PIN: M6 X 28.6, COTTER
11	1015803-0001	4	BEARING: DECK STIFFNESS MECHANISM
12	1022967-0001	2	SPRING: EXTENSION, DECK STIFFNESS
13	1022960-0001	2	NUT: SPRING, EXTENSION
14	1016262-0001	1	ACTUATOR: LINEAR, DC
15,25	1020358-0001	10	SCREW: M10 X 1.5-6G6G X 60, HXS, HEX, C8
16	1022970-0001	2	SCREW: M8 X 1.25 - 6g X 65, HEX, ZN, CLASS 8.8
17	1020234-0001	1	WELDMENT: DECK STIFFNESS
18	1022449-0001	4	BUSHING: DECK STIFFNESS, FRAME GUIDE
19	1022448-0001	2	BUSHING: SPRING CONE
20	0017-00103-0334	5	NUT: M10 X 1.50-6H6H, DIN, LOCKNUT, ST, ZB
21	1021336-0001	1	BRACKET: SWITCH, CUSHIONING HOME
22	1023420-0001	4	ASSEMBLY: CUSHIONING, ARC SPRING

Ref #	Part Number	Qty	Description
23	0017-00101-1961	2	SCREW: M5 X 0.8 X 16, SLT, HXF, TT, ST, ZS
24	1019763-0001	2	MOUNT: CABLE TIE
26	1018021-0001	1	ASSEMBLY: RUNNING METRIC, LEFT
27	0017-00101-1796	8	SCREW: M4.2 X 0.7 6G6G X 19, DIN, PHL, PAN, AB, ST, ZB
28	0017-00042-1180	4	BUSHING: SLEEVE, SNAP
29	1017083-0001	1	ASSEMBLY: RUNNING METRIC, RIGHT
30	0017-00042-1147	8	GROMMET: SCREW, 8 OR 10
31	0017-00032-0195	1	SWITCH: MOMENTARY ACTION
32	6960701	1	LABEL: GROUND
33	0017-00042-0772	2	CABLE TIE: L-15.000 INCH
34	1026190-0001	2	CABLE TIE: MOUNT, WING

Deck, Motor and Rollers

* Note: When replacing deck (14), belt (15), or tecspak springs (20) (23) make sure to order NEW screws (13) and tinnerman clips (19).

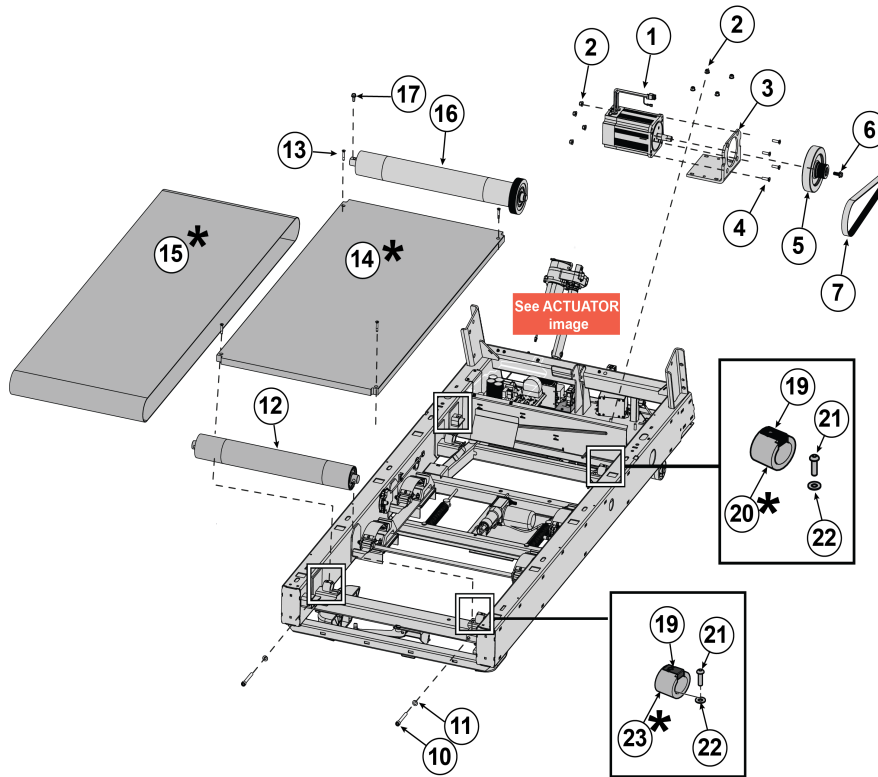

Ref #	Part Number	Qty	Description
1	1015416-0001	1	MOTOR: DC, 4.8 N-M TORQUE
2	1003388-0001	8	NUT: M8 X 1.25-6H, DIN, UNF, HEX, LOCKNUT
3	1016896-0701	1	BRACKET: MOTOR MTG, DC
4	0017-00101-2147	4	SCREW: M8 X 1.25-6G6G X 30, DIN, HEX, FLT, CS, ST
5	1017386-0000	1	FLYWHEEL: PULLEY, POLY V J12, INTEGRAL
6	1005547-0001	1	SCREW: M10 X 1.50 6G6H X 25, UNS, FLG, CS, ST, ZB, W/PATCH
7	1004417-0001	1	BELT: DRIVE
10	1009113-0001	2	SCREW: M10 X 1.5 X 80, SHCS
11	0017-00104-0470	2	WASHER: M10.5 X 20 X 2, DIN, DFLAT, ST, ZB
12	1015961-0001	1	ROLLER: REAR, 88.64 OD
13	1010058-0001	4	SCREW: 1/4-20 X 24, HXS, FLT, L, CS, ST, ZB
14	1015751-0001	1	DECK: TREADMILL, 661.92 WIDE, 25.4 THICK
15	0K65-01002-0000	1	BELT: WALKING NP7131 21.5" WIDE
16	1017143-0001	1	ROLLER: FRONT, 88.64 OD, PJ10 PULLEY
17	1005191-0001	1	SCREW: M8 X 1.25 6G6H X 20, UNS, HXW, CS, ST
19	0017-00103-0198	4	NUT: 1/4 -20, TINNEMAN, ST, ZN
20	0K40-01026-0003	2	SPRING: TECSPAK, ORANGE
21	1005212-0001	4	SCREW: M6 X 1 X 20, HEX, BUT, CS, ST, ZB
22	0017-00104-0072	4	WASHER: 0.255 X 0.562 X 0.046, FLAT, ST, ZN
23	1017824-0001	2	SPRING: ELASTOMER, 63D

Hardware Kit

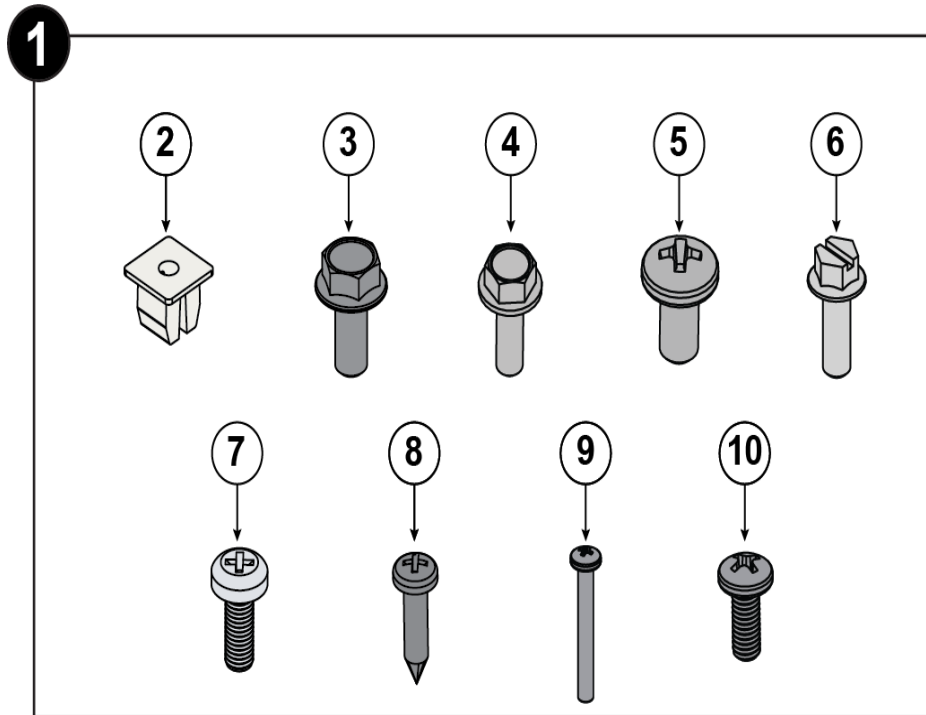

Indicates assembly or kit

Ref #	Part Number	Qty	Description
1	1023985-0001	1	HARDWARE KIT: ASSEMBLY, SYMBIO TREADMILL
2	0017-00042-1147	4	GROMMET: SCREW, 8 OR 10
3	1005191-0001	16	SCREW: M8 X 1.25 6G6H X 20, UNS, HXW, CS, ST
4	1021782-0001	12	SCREW: M6 X 1-6G6G X 20, HXS, HXF, FHB, ST
5	1022792-0001	12	SCREW: M6 X 1.00-6G6G X 12, DIN, PHL, PAN, MS, ST
6	0017-00101-1961	6	SCREW: M5 X 0.8 X 16, SLT, HXF, TT, ST, ZS
7	0017-00101-1972	6	SCREW: M5 X 0.8 X 14, PHL, PAN, MS, ST, BZ
8	0017-00101-1796	4	SCREW: M4.2 X 0.7 6G6G X 19, DIN, PHL, PAN, AB, ST, ZB
9	1025992-0001	4	SCREW: M3 X 0.5 X 12, HXS, CS, ST
10	1017559-0001	2	SCREW: M4 X 0.7 X 10, PHL, PH, ST, BZ

Left Upright

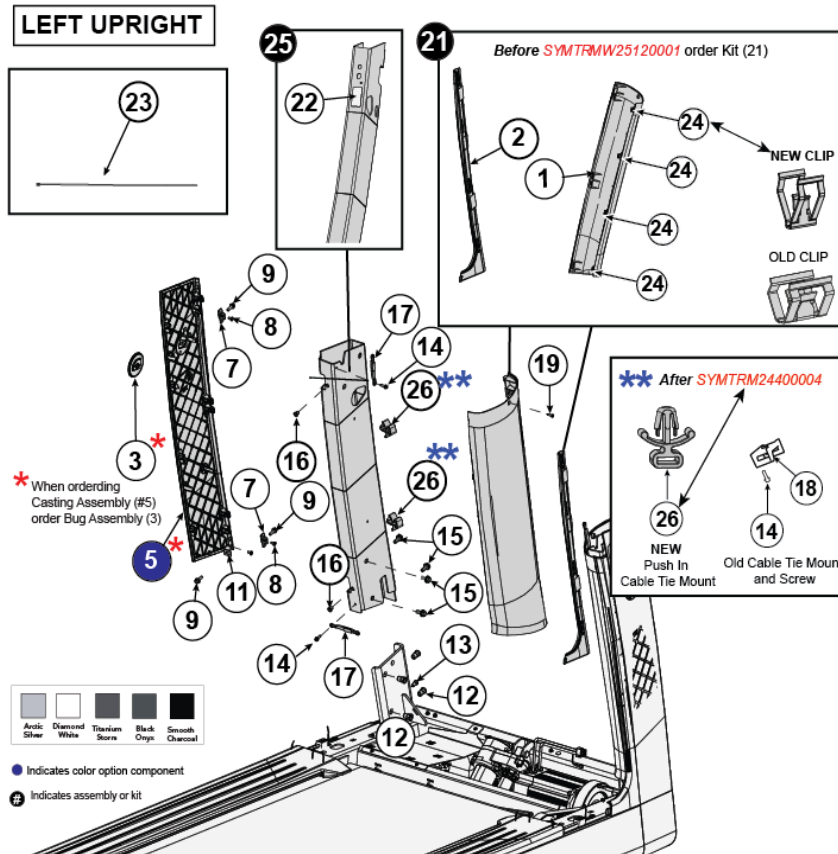

Ref #	Part Number	Qty	Description
1	1018828-0001	1	SHROUD ASSY: UPRIGHT INNER, LEFT
2	1024149-0001	1	ASSEMBLY: SHROUD, SMALL UPRIGHT, LEFT
3	1019548-0001	1	ASSEMBLY: LF LED BUG
5c	1021513-2201	1	CASTING ASSY: UPRIGHT, LEFT, TITANIUM
5a	1021513-0101	1	CASTING ASSY: UPRIGHT, LEFT, ARCTIC SILVER
5b	1021513-2101	1	CASTING ASSY: UPRIGHT, LEFT, PEARLESENT WHITE
5d	1021513-2301	1	CASTING ASSY: UPRIGHT, LEFT, BLACK ONYX
5e	1021513-2601	1	CASTING ASSY: UPRIGHT, LEFT, SMOOTH CHAR GRAY
7	1023464-0001	2	SHEET METAL: BRACKET, SHROUD, UPRIGHT, LEFT
8	1018223-0001	4	SCREW: M5 X 0.8-6H6H X 10, PHL, PAN, CS, ST.
9	1021782-0001	4	SCREW: M6 X 1-6G6G X 20, HXS, HXF, FHB, ST
11	1024145-0001	2	SHEET METAL: BRACKET, CASTING, UPRIGHT, LEFT
12	1019826-0001	4	INSERT: M8 X 7.9, THREADED, HEX
13	0017-00009-1358	1	INSERT: M6 X 6.6, THREADED, HEX
14	0017-00101-1961	4	SCREW: M5 X 0.8 X 16, SLT, HXF, TT, ST, ZS
15	1005191-0001	4	SCREW: M8 X 1.25 6G6H X 20, UNS, HXW, CS, ST
16	0017-00009-1259	2	INSERT: M6 X 5, THREADED, HEX
17	1006261-0001	2	CABLE: GROUNDING BRAID
18	1019763-0001	2	MOUNT: CABLE TIE
19	0017-00101-1796	1	SCREW: M4.2 X 0.7 6G6G X 19, DIN, PHL, PAN, AB, ST, ZB
21	1027521-0001	1	KIT: SHROUDS, UPRIGHT INNER, UPRIGHT SMALL,

Ref #	Part Number	Qty	Description
			LEFT
22	1026012-0001	1	DECAL: "DO NOT OVER TIGHTEN" SYMBIO TREADMILL
23	0017-00042-0772	2	CABLE TIE: L-15.000 INCH
24	1002263-0001	4	CLIP: M9.55 X 16.5, FASTENER, SPRING
25	1025125-0001	1	WELDMENT ASSY: UPRIGHT, LEFT, DECAL
26	1026190-0001	2	CABLE TIE: MOUNT, WING

Leveling Feet

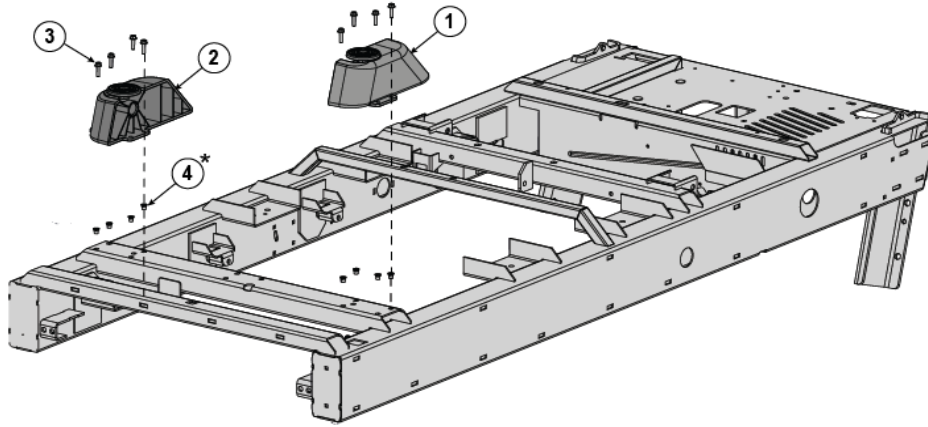

* If needing to replace (4), see the *Life Fitness AVK Replacement Procedure* KB Article.

Ref #	Part Number	Qty	Description
1	1019979-0001	1	ASSEMBLY: FOOT, LEVELING, LEFT
2	1019658-0001	1	ASSEMBLY: FOOT, LEVELING, RIGHT
3	1021782-0001	8	SCREW: M6 X 1-6G6G X 20, HXS, HXF, FHB, ST
4	0017-00009-1259	8	INSERT: M6 X 5, THREADED, HEX

Lift Frame and Com Port

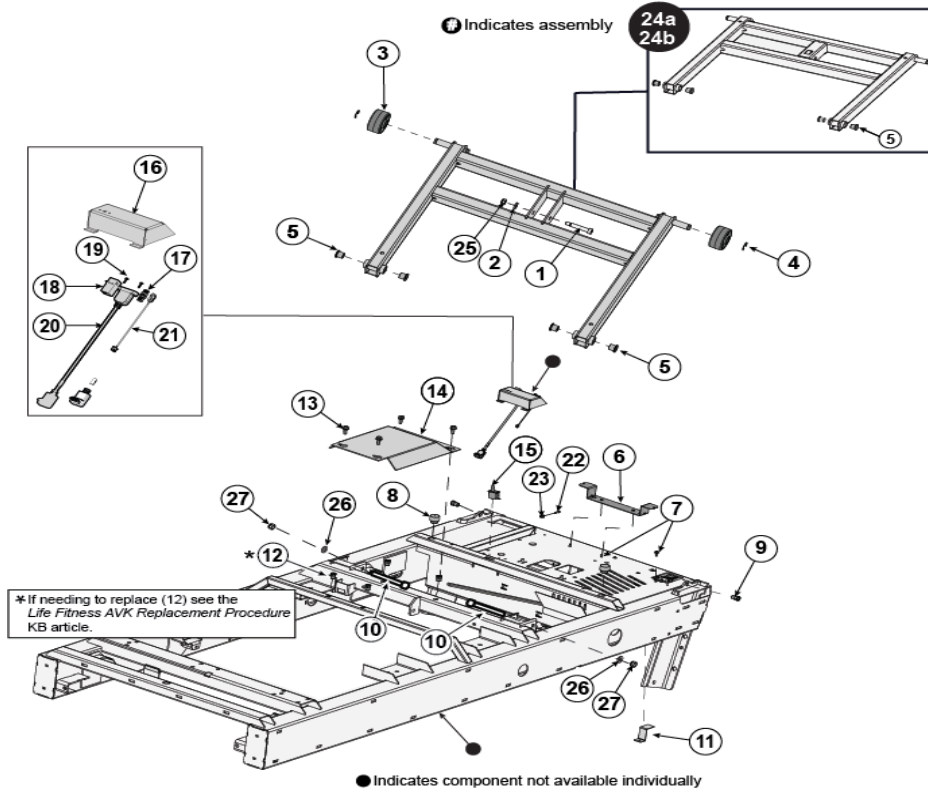

Ref #	Part Number	Qty	Description
1	1026816-0001	1	SCREW: M10 X 1.50 X 55, 12MM DIA, SHL
2	0017-00104-0263	1	WASHER: 0.406 X 0.875 X 0.125, FL, ST
3	0K65-01245-0000	2	WHEEL: LIFT-ARM
4	0017-00100-0249	2	RING: 3/4, ER, ST
5	1016696-0001	4	BUSHING: FLANGE
6	1019386-0001	1	SHEET METAL: POWER CORD, BRACKET
7	0017-00101-2151	7	SCREW: M5 X 0.8 6G6G X 12, FLANGE, HEAD, CS, G5, CD
8	1017398-0001	2	BUMPER: LIFT FRAME HARD STOP
9	1019826-0001	2	INSERT: M8 X 7.9, THREADED, HEX
10	1016695-0001	2	SCREW: M12 X 1.75-6H X 110, HXS, HEX, MS, C8
11	1018313-0001	1	SHEET METAL ASSY: CORD MANAGEMENT
12	0017-00009-1191	4	INSERT: M8 X 6.6, THREADED, HEX
13	1005191-0001	4	SCREW: M8 X 1.25 6G6H X 20, UNS, HXW, CS, ST
14	1017196-0701	1	SHEET METAL: SKID PLATE, BLACK
15	0017-00032-0195	1	SWITCH: MOMENTARY ACTION
16	1018327-0001	1	SHEET METAL: COMPORT
17	0017-00021-2846	1	CONNECTOR: COAX, PANEL MOUNT
18	0017-00021-3195	1	COUPLER: CAT5E, SHIELDED, RJ45
19	0017-00101-2016	2	SCREW: M3 X 0.5 6G6G X 10, DIN, PHL, PAN, E, MS, ST, ZN
20	1001653-0005	1	CABLE ASSY: HDMI, PANEL MOUNT, RIGHT, 1900MM

Ref #	Part Number	Qty	Description
21	1001671-0006	1	CABLE: IR, CONSOLE TO PANEL, 1900MM
22	0017-00101-1796	1	SCREW: M4.2 X 0.7 6G6G X 19, DIN, PHL, PAN, AB, ST, ZB
23	0017-00042-1147	1	GROMMET: SCREW, 8 OR 10
24a	1025541-0701	1	ASSEMBLY: LIFT FRAME, W/BUSHINGS, BLACK, ENGLISH
24b	1025541-0702	1	ASSEMBLY: LIFT FRAME, W/BUSHINGS, BLACK, ARABIC
25	0017-00103-0334	1	NUT: M10 X 1.50-6H6H, DIN, LOCKNUT, ST, ZB
26	1025065-0001	2	WASHER: M12 X 24 X 2.5, FL, C8
27	0017-00103-0332	2	NUT M 12X1.75-6H6H DIN L LOCKNUT ST ZN B

Power Cords

①			96", 244 cm
②			144", 366 cm
③			96", 244 cm
④			102", 260 cm
⑤			144", 366 cm
⑥			144", 366 cm
⑦			144", 366 cm
⑧			144", 366 cm
⑨			144", 366 cm

Ref #	Part Number	Qty	Description
1	0017-00003-0978	1	LINE-CORD: R/A; NEMA 5-20 96" S/C-C
2	0017-00003-0980	1	LINE-CORD: R/A; NEMA 5-20 144 IN. S/C-C
3	0017-00003-0974	1	LINE-CORD: 96"; W/RECP S/C-C
4	0017-00003-0781	1	LINE-CORD: R/A; 220V; USA D
5	0017-00003-0696	1	LINE-CORD: R/A; CEE7; 103" 10A 250V D
6	0017-00003-0890	1	LINE-CORD: U.K; R/A D
7	0017-00003-0996	1	LINE-CORD: IEC; AUSTRALIAN; 230/50 C
8	0017-00003-1054	1	LINE-CORD: BRAZIL, IEC-C19
9	0017-00003-1068	1	LINE-CORD: ARGENTINA, IRAM 2073, IEC-C19

Right Upright

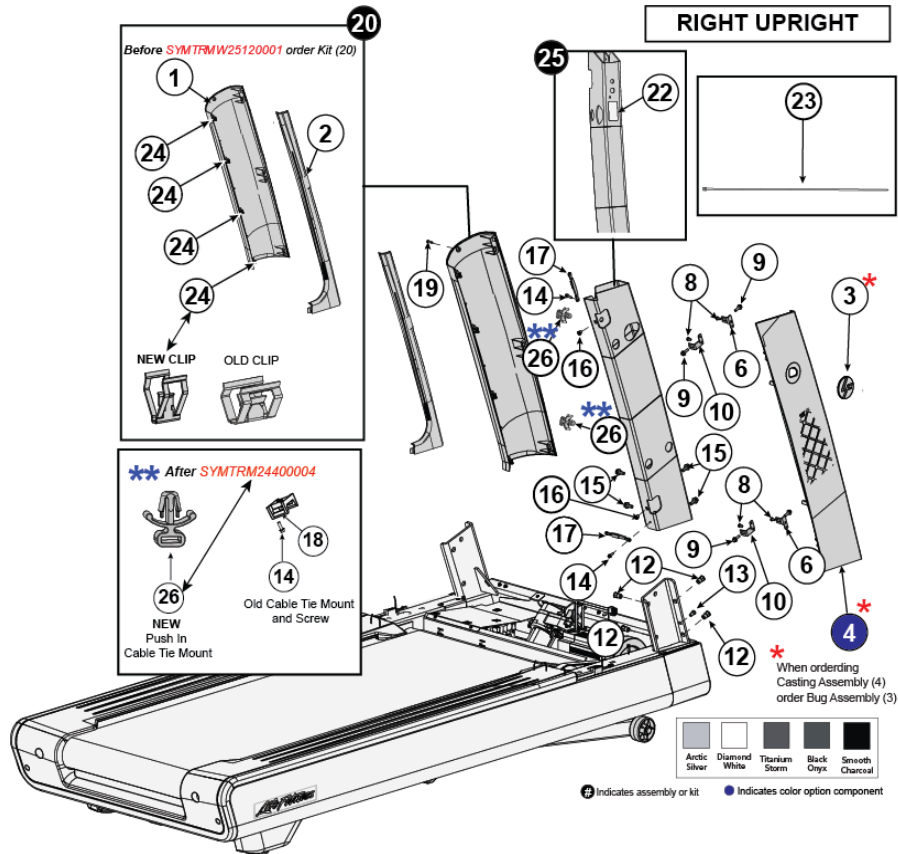

Ref #	Part Number	Qty	Description
1	1018826-0001	1	SHROUD ASSY: UPRIGHT INNER, RIGHT
2	1024148-0001	1	ASSEMBLY: SHROUD, SMALL UPRIGHT, RIGHT
3	1019548-0001	1	ASSEMBLY: LF LED BUG
4c	1021512-2201	1	CASTING ASSY: UPRIGHT, RIGHT, TITANIUM
4a	1021512-0101	1	CASTING ASSY: UPRIGHT, RIGHT, ARCTIC SILVER
4b	1021512-2101	1	CASTING ASSY: UPRIGHT, RIGHT, PEARLESENT WHITE
4d	1021512-2301	1	CASTING ASSY: UPRIGHT, RIGHT, BLACK ONYX
4e	1021512-2601	1	CASTING ASSY: UPRIGHT, RIGHT, SMOOTH CHAR GRAY
6	1023463-0001	2	SHEET METAL: BRACKET, SHROUD, UPRIGHT, RIGHT
8	1018223-0001	4	SCREW: M5 X 0.8-6H6H X 10, PHL, PAN, CS, ST.
9	1021782-0001	4	SCREW: M6 X 1-6G6G X 20, HXS, HXF, FHB, ST
10	1024144-0001	2	SHEET METAL: BRACKET, CASTING, UPRIGHT, RIGHT
12	1019826-0001	4	INSERT: M8 X 7.9, THREADED, HEX
13	0017-00009-1358	1	INSERT: M6 X 6.6, THREADED, HEX
14	0017-00101-1961	4	SCREW: M5 X 0.8 X 16, SLT, HXF, TT, ST, ZS
15	1005191-0001	4	SCREW: M8 X 1.25 6G6H X 20, UNS, HXW, CS, ST
16	0017-00009-1259	2	INSERT: M6 X 5, THREADED, HEX
17	1006261-0001	2	CABLE: GROUNDING BRAID
18	1019763-0001	2	MOUNT: CABLE TIE
19	0017-00101-1796	1	SCREW: M4.2 X 0.7 6G6G X 19, DIN, PHL, PAN, AB, ST, ZB

Ref #	Part Number	Qty	Description
20	1027520-0001	1	KIT: SHROUDS, UPRIGHT INNER, UPRIGHT SMALL, RIGHT
22	1026012-0001	1	DECAL: "DO NOT OVER TIGHTEN" SYMBIO TREADMILL
23	0017-00042-0772	2	CABLE TIE: L-15.000 INCH
24	1002263-0001	4	CLIP: M9.55 X 16.5, FASTENER, SPRING
25	1025126-0001	1	WELDMENT ASSY: UPRIGHT, RIGHT, DECAL
26	1026190-0001	2	CABLE TIE: MOUNT, WING

Service Wheel

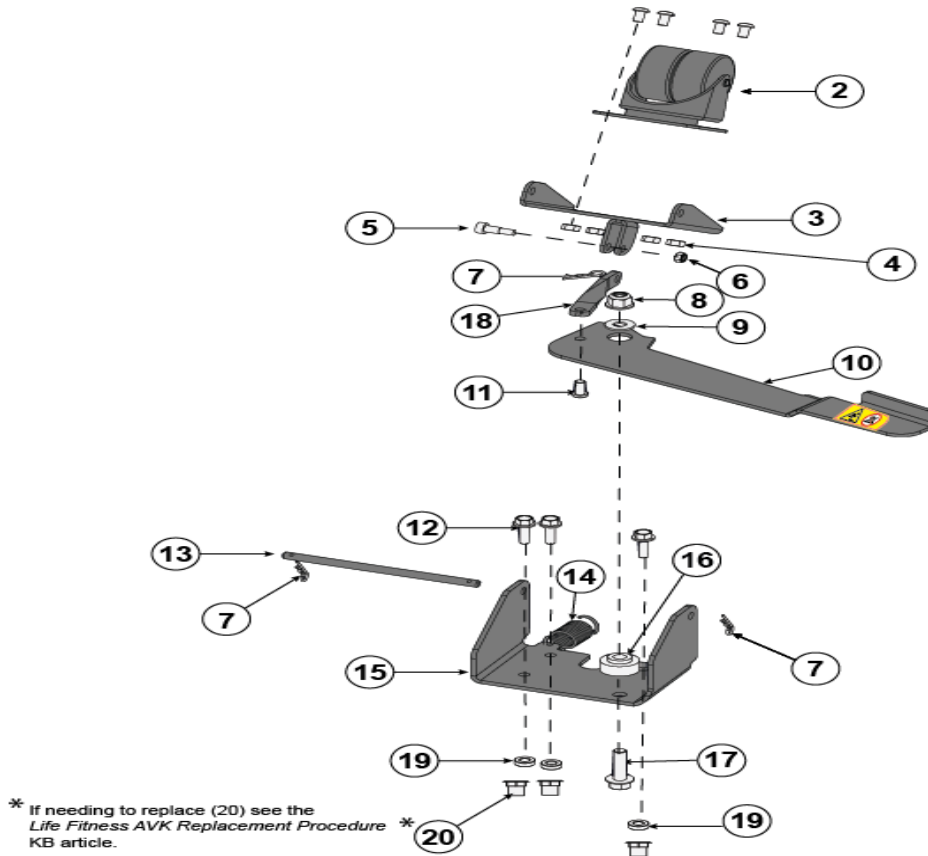

Ref #	Part Number	Qty	Description
1	1006331-0001	4	SCREW: M6 X 1.0 X 10, HXS, BUT, CS, ST, BZ
2	CW-25006	1	CASTOR: SWIVEL, SERVICE WHEEL
3	1006042-0001	1	WELDMENT: WHEEL MOUNT
4	0017-00103-0360	4	NUT: M6 X 1.0, HEX, ST, ZS
5	1006044-0001	1	SCREW: M5 X 0.8, 6MM DIA SHOULDER
6	1006046-0001	1	NUT: M5 NYLOCK
7	1010579-0001	3	PIN: M6 X 28.6, COTTER
8	1003388-0001	1	NUT: M8 X 1.25-6H, DIN, UNF, HEX, LOCKNUT
9	0017-00104-0510	1	WASHER: M8.4 X 19 X 1.6, DIN, FLAT, ST, ZB
10	1027451-0001	1	ASSEMBLY: SERVICE WHEEL, HANDLE KIT
11	1010578-0001	1	PIN: M6.35 X 12.7, CLEVIS
12	1021782-0001	3	SCREW: M6 X 1-6G6G X 20, HXS, HXF, FHB, ST
13	1003609-0001	1	PIN: PIVOT, SERVICE WHEEL
14	1018515-0001	1	SPRING: M19 X 1.91 X 57.15, EXTENSION
15	1017456-0001	1	SHEET METAL: SERVICE WHEEL, FRAME ATTACHMENT
16	1017471-0001	1	SPACER: SERVICE WHEEL
17	0017-00101-2130	1	SCREW: M8 X 1.25-6G6H X 30, UNS, HXW, CS, ST, ZB
18	1003613-0001	1	LINK: TWIST, SERVICE WHEEL
19	1026603-0001	3	SPACER: M6 X 13 X 4, AL
20	0017-00009-1259	3	INSERT: M6 X 5, THREADED, HEX

Side Shrouds

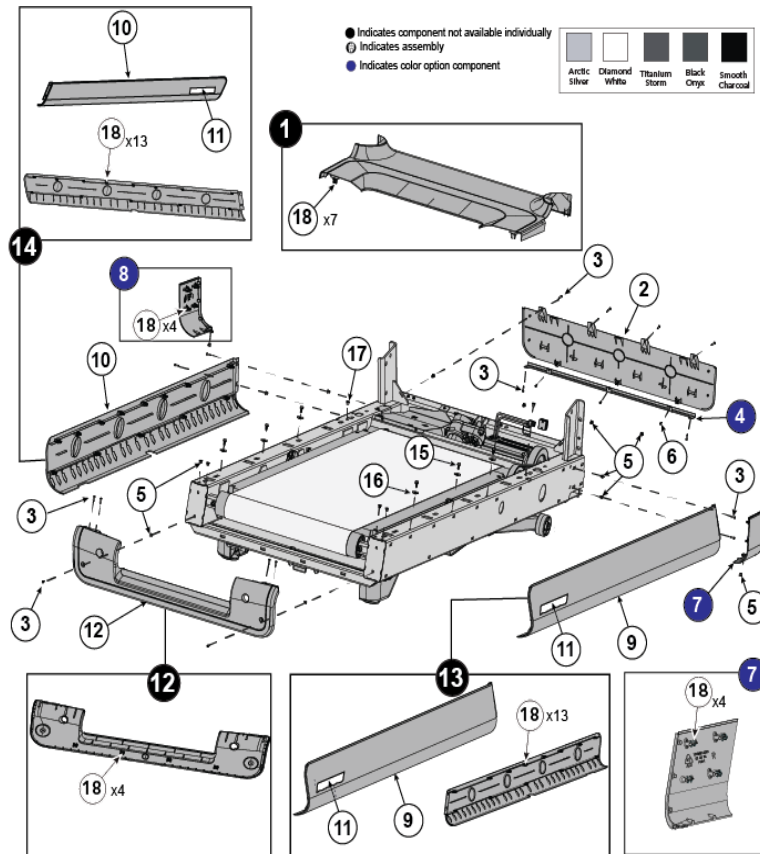

Ref #	Part Number	Qty	Description
1	1018830-0001	1	SHROUD ASSY: MOTOR PAN, TOP
2	1018831-0001	1	SHROUD: MOTOR PAN, FRONT
3	0017-00101-1796	16	SCREW: M4.2 X 0.7 6G6G X 19, DIN, PHL, PAN, AB, ST, ZB
4c	1018879-7101	1	SHEET METAL: MOTOR PAN, BOTTOM MIDDLE, PEARLESENT WHITE ROBUST
4d	1018879-7201	1	SHEET METAL: MOTOR PAN, BOTTOM MIDDLE, TITANIUM ROBUST
4e	1018879-7301	1	SHEET METAL: MOTOR PAN, BOTTOM MIDDLE, METALLIC BLACK ROBUST
4b	1018879-5301	1	SHEET METAL: MOTOR PAN, BOTTOM MIDDLE, SMOOTH CHAR GRAY ROBUST
4a	1018879-5101	1	SHEET METAL: MOTOR PAN, BOTTOM MIDDLE, ARCTIC SILVER ROBUST
5	0017-00042-1147	16	GROMMET: SCREW, 8 OR 10
6	1010103-0001	3	SCREW: M4 X 1.79 X 10, PHL, PAN, PLT, ST, ZC
7b	1018882-2101	1	CASTING ASSY: MOTOR PAN, BOTTOM SIDE, RIGHT, PEARLESENT WHITE
7e	1018882-2601	1	CASTING ASSY: MOTOR PAN, BOTTOM SIDE, RIGHT, SMOOTH CHAR GRAY
7d	1018882-2301	1	CASTING ASSY: MOTOR PAN, BOTTOM SIDE, RIGHT, BLACK ONYX

Ref #	Part Number	Qty	Description
7c	1018882-2201	1	CASTING ASSY: MOTOR PAN, BOTTOM SIDE, RIGHT, TITANIUM
7a	1018882-0101	1	CASTING ASSY: MOTOR PAN, BOTTOM SIDE, RIGHT, ARCTIC SILVER
8a	1018884-0101	1	CASTING ASSY: MOTOR PAN, BOTTOM SIDE, LEFT, ARCTIC SILVER
8c	1018884-2201	1	CASTING ASSY: MOTOR PAN, BOTTOM SIDE, LEFT, TITANIUM
8b	1018884-2101	1	CASTING ASSY: MOTOR PAN, BOTTOM SIDE, LEFT, PEARLESENT WHITE
8d	1018884-2301	1	CASTING ASSY: MOTOR PAN, BOTTOM SIDE, LEFT, BLACK ONYX
8e	1018884-2601	1	CASTING ASSY: MOTOR PAN, BOTTOM SIDE, LEFT, SMOOTH CHAR GRAY
9	1018840-0001	1	SHROUD ASSY: SIDE COVER, RIGHT
10	1018842-0001	1	SHROUD ASSY: SIDE COVER, LEFT
11	1020283-0001	2	DECAL: TR EVEREST LIFE FITNESS LOGO
12	1018838-0001	1	SHROUD ASSY: END CAP, FULL WIDTH
13	1025124-0001	1	SHROUD ASSY: SIDE COVER, RIGHT, DECAL
14	1025123-0001	1	SHROUD ASSY: SIDE COVER, LEFT, DECAL
15	1021126-0001	6	SCREW: M6 X 1 X 16, HXS, HXF, F, ST
16	1022935-0001	6	BUSHING: FLANGE, TOP STEP
17	0017-00009-1259	2	INSERT: M6 X 5, THREADED, HEX
18	1002263-0001	45	CLIP: M9.55 X 16.5, FASTENER, SPRING

Top Steps

● Indicates component not available individually
○ Indicates assembly

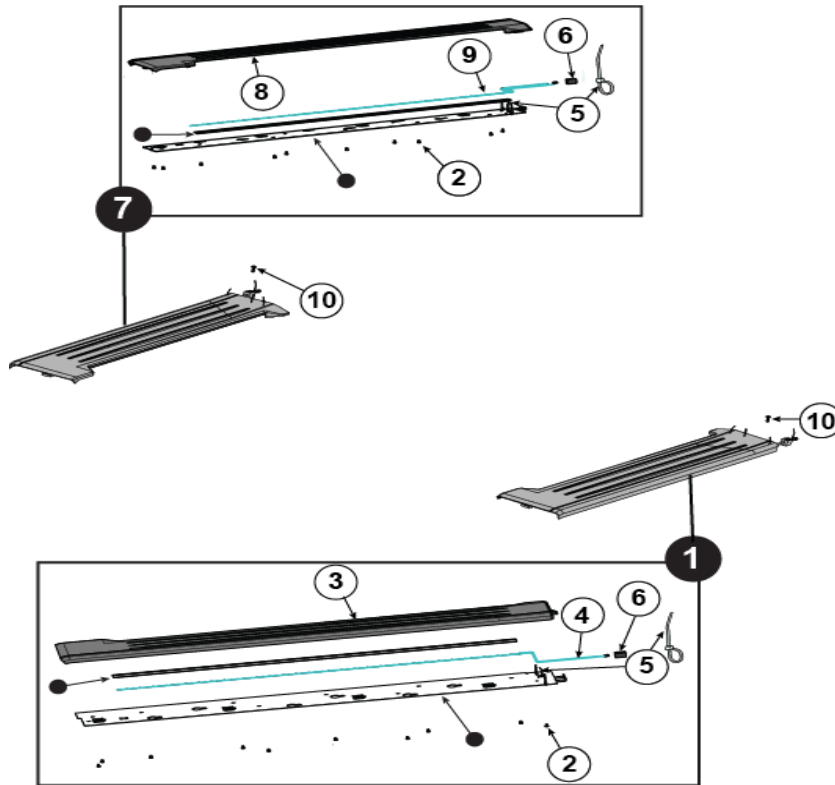

Ref #	Part Number	Qty	Description
1	1018834-0001	1	ASSEMBLY: LED TOP STEP, RIGHT
2	0017-00101-2141	20	SCREW: M5 X 0.8 X 8, PHL, PAN, ST, ZB
3	1020137-0001	1	SHROUD ASSY: LED TOP STEP, RIGHT
4	1020631-0001	1	CABLE ASSY: LED STRIP, TOP STEP, RIGHT
5	0017-00042-0622	4	CABLE TIE: 3-7/8 INCH, S/C-09-B
6	121E-00001-0011	1	FERRITE-BEAD: SUPPRESSION B
7	1018836-0001	1	ASSEMBLY: LED TOP STEP, LEFT
8	1020138-0001	1	SHROUD ASSY: LED TOP STEP, LEFT
9	1020631-0002	1	CABLE ASSY: LED STRIP, TOP STEP, LEFT
10	0017-00101-2138	2	SCREW: M6 X 1.0 X 16, DIN, PHL, PAN, MS, ST, ZB

Upper Assembly Wiring Diagram

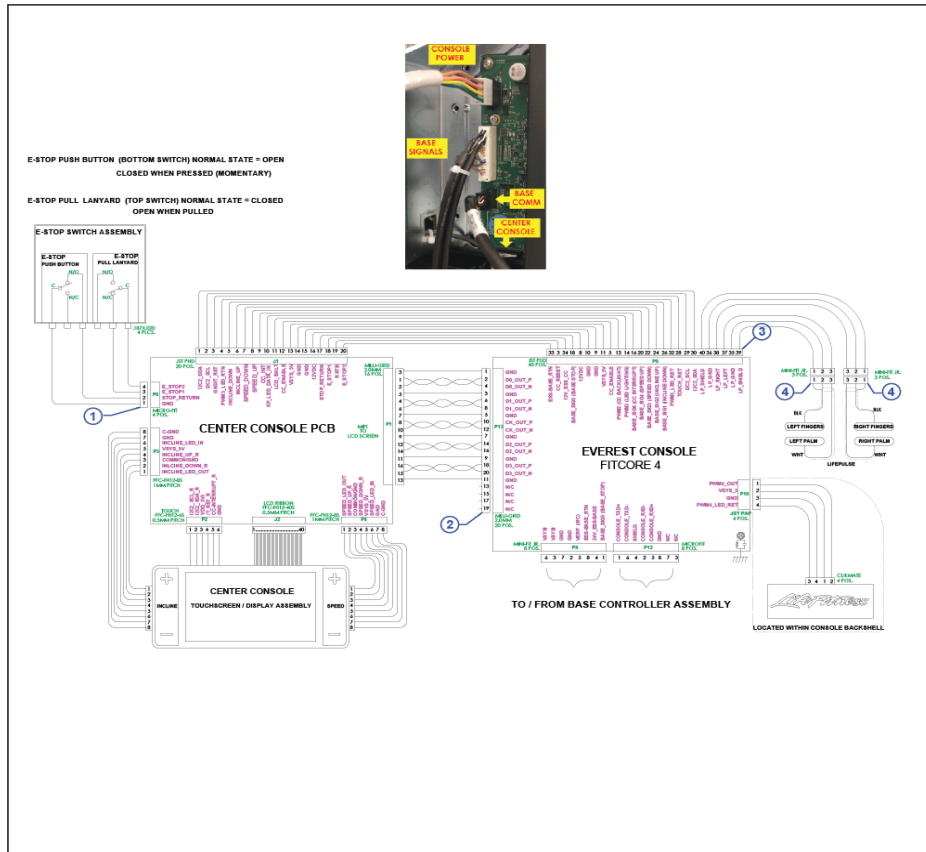

Ref #	Part Number	Qty	Description
1	1020574-0001	1	CABLE ASSY: LIMIT SWITCH TO SIB
2	1019715-0001	1	CABLE ASSY: MIPI
3	1020081-0001	1	CABLE ASSY: ELSE & LP
4	1003871-0002	2	CABLE: LIFE PULSE ELECTRODES, 435MM

